



# 2018 DESIGN SPECIFICATION FOR DISTRIBUTED ANTENNA SYSTEMS

---

Implementation: 01-11-2018

## CONTENTS

FIGURES.....	8
1 PURPOSE.....	10
1.1 Scope.....	10
1.2 Health Safety and Welfare (HS&W) Considerations .....	10
1.3 Lead Carrier Engagement.....	11
2 DAS DESIGN .....	12
2.1 DAS planning .....	12
2.2 design principles .....	12
2.3 General DAS Description .....	13
2.4 SISO/MIMO Design Considerations.....	13
2.5 Operating Frequency Bands .....	14
2.6 Other Frequency Ranges.....	15
2.7 Reference Technologies .....	15
2.8 Future Technologies – 5G.....	16
3 DAS PERFORMANCE CAPABILITY.....	17
3.1 Passive DAS .....	17
3.2 Active DAS.....	17
3.3 Target Coverage Area.....	17
3.4 RF Levels Required .....	17
3.4.1 Building Core and Lift Well Coverage.....	19
3.5 Handover Zone .....	19
3.6 Design Solutions for Various DAS Applications .....	20
3.7 Types of In Building Coverage Solutions .....	20

3.7.1	Introduction .....	20
3.7.2	Residential Apartments.....	21
3.7.3	Serviced Apartments.....	22
3.7.4	Hotels.....	23
3.7.5	Commercial Office .....	24
3.7.6	Shopping Centre.....	24
3.7.7	Convention Centres .....	25
3.7.8	Stadiums.....	25
3.7.9	Airports .....	26
3.7.10	Rail Tunnels.....	26
3.7.11	Motorway Tunnels .....	27
3.7.12	Hospitals .....	27
3.8	Passive DAS Interconnect Ports .....	28
3.9	Active DAS Interconnect Ports .....	29
3.10	EME Design Constraints .....	29
3.11	Electromagnetic Compatibility (EMC) Design Constraint .....	30
3.12	Maximum Signal Received by User Equipment (UE) .....	32
3.13	Minimum Allowable Path Loss .....	32
3.13.1	Passive DAS.....	32
3.13.2	Active DAS.....	33
3.14	RF Propagation Model .....	33
3.15	Measured Performance of Installed DAS .....	33
3.15.1	Return Loss .....	34
3.15.2	Passive Intermodulation (PIM).....	34

3.15.3	Frequency Response.....	34
3.15.4	Propagation Delay .....	34
3.15.5	System Uplink Noise Performance .....	35
3.16	Cable and Component Labelling.....	35
3.17	Approved Material List .....	35
3.18	DAS Component Specifications .....	36
3.18.1	Characteristic Impedance .....	36
3.18.2	Component Return Loss .....	36
3.18.3	Component PIM Performance .....	36
3.18.4	Coaxial Connector Types.....	37
3.18.5	Coaxial Cables.....	37
3.18.6	Cables with Braid, Foil or Foil/Braid Screening.....	38
3.18.7	Antennas.....	38
3.18.8	GPS Antennas .....	38
3.18.9	Cables that Support Remote or Active Equipment.....	41
4	DELIVERABLES.....	42
4.1	Documentation .....	42
4.1.1	Submission of Documents .....	42
4.1.2	Copyright and Ownership of DAS Design Information .....	42
4.1.3	File Types and Document Security .....	42
4.2	Preliminary DAS Design Documentation for Lead Carrier Review .....	43
4.3	Detailed DAS Design Documentation for Lead Carrier Approval .....	44
4.4	For Construction Installation Documentation.....	45
4.5	Handover Documentation.....	47

5	PASSIVE INTERMODULATION (PIM).....	48
5.1	What is Passive Intermodulation (PIM)? .....	48
5.2	What issues does it cause to a DAS? .....	49
5.3	How do PIM problems typically arise? .....	50
5.3.1	Poor Quality Components.....	51
5.3.2	Poor Workmanship .....	51
5.3.3	Inappropriate Placement of Antennas.....	51
5.4	Recommendations to Minimise PIM.....	52
6	INSTALLATION GUIDELINES .....	54
6.1	Cable Handling.....	54
6.1.1	Passive Backbone .....	55
6.1.2	Active Backbone .....	56
6.1.3	Branch (Floor) Cabling.....	57
6.1.4	Cable Bending Radius .....	57
6.1.5	Cable Tensile Strength .....	58
6.1.6	RF Connectors.....	58
6.1.7	Feeder Cable Mounting (Non-Radiating Cable).....	59
6.1.8	Radiating Cable Mounting.....	59
6.2	Antenna Installation.....	59
6.2.1	Mounting of Omnidirectional Antennas .....	60
6.2.2	Mounting of Panel Antennas.....	61
6.3	Splitter Mounting .....	62
6.4	Jumper Cables .....	63
6.5	Optical Fibre Installation Guidelines.....	64

6.5.1	Optical Fibre Cabling in Equipment Rooms .....	64
6.5.2	Remote Unit Cabling.....	65
6.6	Optical Fibre Cable Installation .....	66
6.7	GPS Antennas .....	67
7	TEST RESULTS.....	67
7.1	Installation / Test Report .....	67
7.2	Test Equipment Used.....	68
7.3	RF Sweeps.....	68
7.4	Insertion Loss.....	69
7.5	Passive Intermodulation Testing.....	70
7.6	Walk Tests .....	71
7.6.1	Walk Test Route .....	72
7.6.2	Walk Test Measurements .....	73
7.6.3	Walk Test Results.....	73
7.6.4	Lift Car Vertical Plots .....	74
7.7	Optic Fibre Testing & Commissioning .....	75
7.7.1	Optical Time Domain Reflectometer (OTDR).....	75
7.7.2	Section Link Length .....	75
7.7.3	OTDR Link Loss .....	75
8	CARRIER EQUIPMENT & ACCOMMODATION REQUIREMENTS .....	76
8.1	Carrier Room Specifications.....	76
8.2	Carrier Equipment Rack Space Requirements.....	76
8.3	Power.....	76
8.3.1	Surge and Lightning protection .....	76

8.3.2	Auxiliary Power and Redundancy .....	77
8.3.3	Power Supply to Air Conditioning .....	77
8.4	Air Conditioning.....	77
8.5	Fire Protection.....	78
8.6	Cable Management.....	78
8.7	Remote Multi-Network Combiner (MNC) Locations .....	78
8.8	Transmission.....	79
8.9	Lighting.....	79
8.10	Room Finish.....	79
8.10.1	Room Finish Summary Table .....	80
8.11	DAS Security.....	80
8.11.1	Security of Power and Transmission to Remote Equipment Locations.....	80
9	DEFINITIONS.....	81

## TABLES

Table 1	Bands designated for use by mobile network operators	15
Table 2	Reference Technologies and 3GPP Standards	16
Table 3	potential 5G Bands under Consideration	16
Table 4	Signal, Dominance and Quality Performance Levels for DAS	18
Table 5	Types of DAS and target bands	19
Table 6	Maximum Input Power	29
Table 7	Electromagnetic Interference (EMI) Limits	31

Table 8 Distance from antenna for E field limits	32
Table 9 Maximum Received Levels at MS/UE	32
Table 10 Minimum allowable path loss	33
Table 11 Passive Component PIM Specification	37
Table 12 Permitted Coaxial Connector Types	37
Table 13 Installation/Test Report	68
Table 14 Example of Insertion Loss Report	70
Table 15 Walk tests to be conducted for all technologies and frequency bands which will operate from DAS handover	73
Table 16 Room Finish Summary Table	80

## FIGURES

Figure 1 MNC Configuration Diagram	29
Figure 2 Ideal GPS Antenna View of Sky	39
Figure 3 Minimum GPS Antenna View of Sky	39
Figure 4 GPS Line of Site - Horizontal Plane	40
Figure 5 Passive Intermodulation (PIM) Products Produced by Two Signals	48
Figure 6 Noise Floor Tolerances between Communications Generations	49
Figure 7 Poor PIM Performance on Base Station Receiver	50
Figure 8 Initial and Improved Installation to Reduce Stress on RF Connections and Improve Testability	53



Figure 9 Typical Cable Installation on Tray	55
Figure 10 Distribution from backbone cable	56
Figure 11 Branch (Floor) Cabling	57
Figure 12 Floor Cable Mounting	59
Figure 13 Omnidirectional antenna Installation below false ceiling	60
Figure 14 Omnidirectional antenna mounted where no false ceiling exists	61
Figure 15 Mounting of panel antennas	61
Figure 16 Example of splitter / coupler mounting bracket	62
Figure 17 Typical Installation	63
Figure 18 Optic Fibre Rack-mounted Splice Tray and Patch Panel	65
Figure 19 Optic Fibre Splice Tray and Patch Panel	66
Figure 20 Optic Fibre Splice Box	66
Figure 21 Example of a Return Loss Sweep	69
Figure 22 Example of colour-coded snail trail result	74

## 1 PURPOSE

Distributed Antenna Systems (DAS) are used to provide enhanced mobile coverage and capacity management by using antennas strategically distributed within the proposed coverage area. The DAS consists of the cabling, splitting and radiating elements (antennas) required for such coverage solutions. These distributed antenna systems are used for various applications, however are ideally suited to provide an indoor coverage solution in situations where the external mobile network base stations may not provide reliable penetration to all areas within a building.

When properly designed and installed, the installation of a DAS provides the ideal opportunity to ensure end-users receive an optimal quality experience. Conversely a poorly designed or badly installed system will see end-users encounter unreliable user experiences such as dropped calls, clipped speech, slow data speed etc.

This specification document outlines the design standards and performance quality criteria required to ensure end-users receive a carrier-grade service from the DAS.

### 1.1 SCOPE

This document details the design, performance and test results for a DAS to which mobile operators will agree to connect their radio communications equipment.

Where the DAS is comprised of more than one sector, the standards outlined in this document shall apply to each sector. These standards will apply to passive, active and hybrid DAS's.

This document provides carrier requirements from a design, engineering and operational perspective. The document does not contemplate tenure or other commercial arrangements.

### 1.2 HEALTH SAFETY AND WELFARE (HS&W) CONSIDERATIONS

This document provides information required to ensure a DAS can be designed and installed to meet the relevant workplace safety standards, however this document must be considered subordinate to any general or project specific HS&W requirements.

In situations where there appears to be a conflict or contradiction between this document and any other workplace safety standards, the more conservative (i.e. the safer) solution should apply.

The DAS design process must address EME levels in line with mandatory standards.

The Lead Carrier will be the party who becomes accountable for ongoing operation and maintenance of the DAS and accordingly the Lead Carrier must be consulted to answer or determine the most appropriate resolution to any conflicts which may be identified during the DAS design or installation processes.

### 1.3 LEAD CARRIER ENGAGEMENT

The building owner or developer must seek the engagement of a Lead Carrier either via the MCF or by direct approach to the Lead Carrier prior to issuing a tender for the construction of a DAS. If no carrier has agreed to be Lead Carrier or is willing to review design, then DAS design still must proceed to the standards contained in this document. The lead carrier can enter into an NDA should confidentiality be a requirement

- 1) Lead Carriers have the responsibility to approve a DAS design and will be accountable for any DAS performance deficiency which may arise as a consequence of that lead carrier approval. (Note: the Lead Carrier will not be accountable for deficiencies in DAS performance that arise from changes in building design which have not been explicitly notified to the Lead Carrier and which impact performance of the DAS.)
- 2) The DAS design may or may not be sourced from a Lead Carrier.
- 3) Lead Carriers will provide the opportunity for other Carriers to review the efficacy of the proposed design in relation to their networks at the time of the review and must take into consideration other Carrier's reasonable requirements within the scope of these specifications.
- 4) If other Carriers do not respond within 10 working days of an invitation from the nominated Lead Carrier, the assumption will be made that such Carriers have no interest in the design proposal.
- 5) If the design is deemed non-compliant with these guidelines by the Lead Carrier, the Lead Carrier will identify the deficiencies which must be addressed and inform the DAS designer, building developer and building owner.

## 2 DAS DESIGN

### 2.1 DAS PLANNING

Before beginning the detailed design of a DAS, the designer must follow these steps.

- 1) The design must evaluate the coverage levels (in consultation with the Lead Carrier) provided by the surrounding cells, taking into account any proposed network changes that are likely to cause an impact. Refer “Exclusion Zones” later in document.
- 2) The design must take into account any technical, structural or architectural constraints.
- 3) The design must comply with any applicable regulatory conditions (building codes, electrical safety etc.).
- 4) Future proofing of the DAS for all Carriers and all technologies, where possible and where necessary.

### 2.2 DESIGN PRINCIPLES

The DAS must be designed with these six key principles in mind.

- 1) Provide enhanced coverage, and a consistent user experience within the target coverage area.
- 2) Provide dominant coverage within the target coverage area to avoid unnecessary hand-off and/or interference to/from the rest of the network.
- 3) Provide sufficient capacity for the size of the building and expected occupancy, with reasonable allowance for network traffic growth. DAS shall be designed so that it can be easily expanded and upgraded for capacity reasons by way of sectorisation or similar, without compromising the DAS performance.
- 4) Be engineered to allow interference-free operation between the Sharing Carriers.
- 5) Provide for inter-operability with each of the Sharing Carrier’s macro networks. Each operator should be able to operate their network without adverse impact from the other sharing operators
- 6) Must be able to operate in accordance with ACMA licence conditions.

Designers need to be mindful of the population distributions between floors and service areas, such as car parks, lobbies, etc. within a building when calculating the number of sectors required for capacity in particular areas of a building.

As indicated in other locations in this document, the DAS should be able to be sectorised and doubled in the number of sectors without significant redesign impacts other than to the first common element of the system.

Passive DAS designs should be used where it can be demonstrated that they are fit for purpose (i.e. meets the coverage and capacity requirements of the Sharing Carriers).

Active DAS sections can be used where it can be demonstrated that it provides a better coverage solution in the building environment. This may also be the case where the end user customers require enhanced solutions, where installation constraints exist, or where the link budget for a purely Passive DAS design is insufficient.

### 2.3 GENERAL DAS DESCRIPTION

The Distributed Antenna System (DAS) is shareable architecture which may be described as either:

- 1) Passive – where the base station signal is distributed to the antennas via a passive network of coaxial cables, splitters and couplers.
- 2) Active – where the base station signal is connected to a central hub or interface unit, which then feeds a network of either optical fibre cables, or dedicated structured cabling. Each of these cables in turn connects to an active RF head and antenna.
- 3) Hybrid – being a combination of Passive and Active Elements

### 2.4 SISO/MIMO DESIGN CONSIDERATIONS

Multiple Input Multiple Output (MIMO) systems utilise multiple radio paths between Mobile Network Operator's radio base stations and customer mobiles to enhance performance and capacity.

In contrast to MIMO, Single Input Single Output systems (SISO) use one radio path.

The Lead Carrier will determine SISO or MIMO requirements when they assess the required performance attributes for a DAS. The Lead Carrier can present a business case the DAS

developer to support the technical requirements for MIMO. The end decision will be in consultation with the customer and the Lead Carrier.

Typical candidates for a MIMO DAS configuration are locations which cater for large numbers of people congregating in relatively small and uncluttered areas such as stadiums, entertainment/exhibition/convention centres, auditoriums, function centres, transport/railway tunnels, underground platforms and airports.

Office buildings, apartments, hotels etc. will generally be considered acceptable with SISO design unless there are particular unique circumstances

## 2.5 OPERATING FREQUENCY BANDS

In Australia, the following bands are currently designated for use by mobile network operators under both Spectrum and Apparatus Licences (PTS) which are administered by the ACMA

Band	3GPP Band	Frequency (MHz)	Reference Technology	Alternate Technology
<b>700 MHz</b>	28	DL: 758 to 803 UL: 703 to 748	LTE	<i>none</i>
<b>800 MHz</b>	5	DL: 870 – 890 UL: 825 - 845	WCDMA	<i>LTE</i>
<b>900 MHz</b>	8	DL: 935 – 960 UL: 890 - 915	LTE <sup>1</sup>	<i>WCDMA<sup>1</sup></i>
<b>1.8 GHz</b>	3	DL: 1805 – 1880 UL: 1710 – 1785	LTE	<i>none</i>
<b>2.1 GHz</b>	1	DL: 2110 – 2170 UL: 1920 - 1980	WCDMA	<i>LTE</i>

Band	3GPP Band	Frequency (MHz)	Reference Technology	Alternate Technology
<b>2.3 GHz</b>	40	2300 – 2400	TD-LTE	<i>none</i>
<b>2.5 GHz</b>	7	DL: 2620 – 2690 UL: 2500 - 2570	LTE	<i>none</i>

Table 1 Bands designated for use by mobile network operators

Note 1: Preference for reference technology in 900 MHz band (Band 8) varies between operators. Consult with Lead Carrier.

For maximum flexibility, the passive components of the DAS must be selected to allow operation on all available bands. Active systems must have the flexibility to operate on all of these bands, and be commercially available at the time of deployment. Exceptions to this requirement must be agreed by the Sharing Carriers.

## 2.6 OTHER FREQUENCY RANGES

Where provision is required for cellular bands not listed in Table 1, components that cover the required frequency range, technology and use-case should be specified. Non-cellular services such as land-mobile, paging and Wi-Fi must be deployed on separate infrastructure unless specifically agreed by the Lead Carrier.

If agreed by the Lead Carrier, the non-mobile services must be properly integrated and incorporated from the initial design phase, rather than being subsequently added to the DAS. Retrofit solutions for non-mobile services are not permitted as they may compromise overall DAS performance.

## 2.7 REFERENCE TECHNOLOGIES

DAS shall be designed to operate with base station and repeater equipment that is compliant with the corresponding ACMA licence conditions, as well as the relevant 3GPP standards.

Reference Technology	3GPP Series
WCDMA	<a href="#">TS 25 series</a>
LTE	<a href="#">TS 36 series</a>

Table 2 Reference Technologies and 3GPP Standards

## 2.8 FUTURE TECHNOLOGIES – 5G

During the preparation of this specification document there has been a lot of speculation in the industry about 5G technologies. The industry continues to focus on 5G applications in the macro environment rather than in-building. Accordingly, there is not much detail to enable Carriers to provide guidance on “future-proofing” a DAS for generational technology change.

The information currently available suggests that most current DAS equipment won’t support 5G technology. In order to support the high bandwidths associated with 5G technologies, there will need to be a greater reliance on optic fibre to transport data to remote radio heads around a building.

Traditional DAS using passive, active or passive/active hybrid architecture is unlikely to support 5G.

Band	3GPP band	Frequency (MHz)	Reference Technology	Alternate Technology
3.5 GHz	42	3400-3575	LTE	Potential 5G
3.6 GHz	43	3575-3700	Potential 5G	Potential 5G

Table 3 potential 5G Bands under Consideration

The best interim measure to prepare for 5G will be to provision and install a dedicated and robust fibre backbone throughout the building. Despite the seemingly high capacity of fibre, this fibre must be entirely dedicated to mobile in-building communications to ensure scalability, security and future performance can be delivered.



### 3 DAS PERFORMANCE CAPABILITY

#### 3.1 PASSIVE DAS

All components and elements of a passive DAS must be designed to simultaneously distribute the range of frequencies and technologies identified in Table 1.

The number of Sharing Carriers and the expected number of RF signals (channels) in each frequency band shall be established prior to the commencement of the design.

#### 3.2 ACTIVE DAS

Active DAS equipment must be operationally supported by the Lead Carrier. It should not be assumed that all products offered by vendors are acceptable for connection by the carriers. Acceptability to the Lead Carrier needs to be confirmed before any purchase decisions are made.

The number of Sharing Carriers and the number of channels per Carrier in each frequency band shall be established prior to the commencement of the design in consultation with the Carrier prior to design and build.

The design shall assume that all channels in every frequency band are in operation simultaneously and at maximum forward power at each output port of the Active remote head.

#### 3.3 TARGET COVERAGE AREA

The Target Coverage Area shall be agreed with the Lead Carrier prior to commencement of the DAS design and shall be documented and marked on copies of the site plan and floor plans. This is undertaken in consultation with the Carrier prior to design and incorporating the developers coverage requirements.

In any situation where a reduction in the Target Coverage Area has not been agreed upfront, the Lead Carrier must assume the Target Coverage Area encompasses the entire building in accordance with the performance levels detailed in 3.4 below before accepting handover of the DAS.

#### 3.4 RF LEVELS REQUIRED

The DAS must provide dominant coverage within the Target Coverage Area to avoid unnecessary hand-offs and/or interference to/from the external mobile network and must also deliver high

quality signal within the Target Coverage Area. The external mobile network is defined as any mobile network signal received/measured/identified within the Target Coverage Area which is not part of the DAS itself. This is undertaken in consultation with the Lead Carrier.

Table 4 specifies the required signal, quality and dominance levels for various technologies These values need to be reliably achieved and available to >95% of the Target Coverage Area.

Table 5 specifies the DAS performance benchmarks for the various DAS types

RF levels for the DAS design will vary according to the location within the building. For example, the influence of the external macro network is likely to be greatest in proximity to the perimeter walls and windows. The DAS design will need to particularly ensure performance from the DAS meets required criteria in these locations.

In situations where the end-state external mobile network signal levels cannot be reliably measured (e.g. a building not yet constructed or external façade has not been installed), the Lead Carrier must be engaged to provide appropriate reference signal levels to be used for design purposes. The Lead Carrier shall provide signal levels for each building level of each building elevation.

	DAS Signal Dominance (dB) (vs. External Mobile Network)	WCDMA		LTE	
		RSCP (dBm)	Ec/10 Unloaded (dB)	RSRP (dBm)	SINR (dB)
4G criteria	≥10	-	-	≥-95	≥15
3G criteria	≥9	≥-85	≥-7	-	-

Table 4 Signal, Dominance and Quality Performance Levels for DAS

	Indoors (DAS Performance in Target Design Coverage Areas) plus all lower bands		
	3G 2100	4G 1800	4G 2600
Residential Serviced Apartments Hotels	Yes	Yes	Yes
Commercial Office Buildings Shopping Centres	Yes	Yes	Yes
Hospitals	Yes	Yes	Yes

	Indoors (DAS Performance in Target Design Coverage Areas) plus all lower bands		
	3G 2100	4G 1800	4G 2600
Convention Centres	Yes	Yes	Yes
Stadiums	Yes	Yes	Yes
Airports	Yes	Yes	Yes
Rail Tunnels (inside train)	Yes	Yes	Yes
Motorway Tunnels (inside vehicle)	Yes	Yes	Yes

Table 5 Types of DAS and target bands

Note: Carrier to confirm that 95% coverage target of -95dBm can be achieved at 4G 2600. Coverage at a distance 6m outside the building at ground level from the IBC must be low enough to ensure dominance by each operator’s macro network and must exceed the macro network by 10dB.

The dominance of external macros is extremely important to DAS performance. A Lead Carrier must be consulted in the determination of Exclusion Zones, otherwise the coverage levels must exceed the minimum levels in Table 4 RF Signal, Dominance and Quality Performance Levels for DAS, by at least 10dB

### 3.4.1 BUILDING CORE AND LIFT WELL COVERAGE

Where there are lifts within the Target Coverage Area, it is recommended that antennas be placed in the lift foyer adjacent to the lift core (minimum one antenna per every three adjacent lifts). Placement of the antennas should be done in consultation with the Lead Carrier. RF power levels to each antenna must be the maximum allowable based on EME constraints, and must be sufficient to provide “best effort” 3G and 4G coverage into lifts, and must factor the combined RF loss from the lift walls and lift shaft walls.

In order to avoid triggering undue hand-offs, sector design for the DAS must consider the impact of lifts rapidly travelling through different sectors and the abrupt closure of lift doors.

### 3.5 HANDOVER ZONE

RF levels shall be sufficient to facilitate both-way handovers with the external mobile network at locations agreed on the Target Coverage Area.

The design should ensure that RF levels specified in Section 3.4 at ground level outside the building are met.

With the exception of DAS applications being installed specifically for transport infrastructure (tunnels, railway stations etc.), handovers to/from external fast moving mobiles need to be avoided. For tunnels etc., coverage should be extended to ensure seamless handover to the macro network.

Satisfactory mitigation of signal leakage from the DAS out to the external mobile network must be demonstrated and approved by the Lead Carrier during DAS design in circumstances where buildings or DAS infrastructure are situated in close proximity to freeway overpasses, train lines or similar situations where inadvertent handover to external mobile network users passing the DAS at speed has the potential to impact performance.

## 3.6 DESIGN SOLUTIONS FOR VARIOUS DAS APPLICATIONS

The design solution which will be most appropriate for a particular DAS varies depending on the application. Specifically, a DAS for a mine or railway tunnel will not apply the same design approach as may be required for a stadium. Likewise a residential apartment building DAS must address requirements differently to a commercial office environment.

To the extent it is possible to apply, the approaches to various DAS solutions discussed within this section must form the basis of a DAS design for the topics covered in this section.

## 3.7 TYPES OF IN BUILDING COVERAGE SOLUTIONS

### 3.7.1 INTRODUCTION

In situations where external mobile networks cannot supply reliable indoor coverage and it is necessary to provide RF coverage augmentation, the nature of the building and a variety of circumstances will determine the most appropriate coverage solution.

The particular DAS design considerations and objectives which will be considered by the Lead Carrier as part of assessing the most appropriate coverage solution for a given application type are outlined below.

The reduction in use of fixed line (PSTN) communication services for residential and business use means communication solutions for people's everyday needs must be carefully considered by developers and builders. In areas where external carrier macro network coverage will not be

reliable for indoor residential apartments or business use, the possible solutions include: fixed lines (PSTN/NBN), VoWiFi, Small Cells, Carrier-approved Smart Antennas or DAS solutions.

A DAS is designed to provide equivalent performance between all carriers throughout the system. The Lead Carrier is responsible for overseeing design of the DAS. After the Lead Carrier agrees to accept the DAS, the Lead Carrier is the party which becomes accountable to resolve any performance issues or deficiencies which are identified in the system.

---

### 3.7.2 RESIDENTIAL APARTMENTS

Wherever possible the DAS should be designed with antennas and infrastructure being placed outside the apartments (i.e. in common areas) to provide service to the Target Coverage Areas within the apartments.

Where the placement of antennas in building common areas will not provide sufficient performance to the Target Coverage Areas, it is important for all stakeholders to acknowledge that difficulty for the Lead Carrier to gain access to private residential apartments when required will inevitably lead to delays in rectifying faults on DAS in residential buildings. Consequently the DAS must be configured so each apartment has a unique feed which can be physically isolated from the remainder of the DAS from outside the apartments – i.e. accessible from common areas of the building.

It is not permitted for any branch of the DAS to service multiple apartments without the ability to inspect and isolate each individual apartment being serviced by that branch from common areas.

Reason: Supports DAS fault-finding without needing to access private residences and helps mitigate PIM contamination affecting other parts of the DAS.

All residential layouts are unique and the extent of Targeted Coverage Areas within apartments will depend on size, apartment layout, and even building exclusivity. For the best possible user experience, the generic approach to providing contiguous coverage within apartments should be prioritized as follows;

- i) Communal living areas;
- ii) Offices;
- iii) Entries/hallways;
- iv) Kitchens;

- v) Bedrooms;
- vi) Bathrooms/laundries

With respect to antenna positioning, residential apartments typically have very confined false-ceiling space due to the number of services being run inside ceiling cavities, such as plumbing, air-conditioning and electrical. The confinement and density of these services is regularly identified as a significant cause of PIM.

The currently available PIM-compliant DAS antennas mean that aesthetics may be an issue for some developers or architects.

On this issue, designers are specifically directed to Section 6.2. While proposals may be considered by the Lead Carrier, it should be noted that attempts to fully conceal antennas inside the ceiling space, or with the use of “low-profile” antennas which do not have a robust back-plane to limit RF energy resonating within the false ceiling space are unlikely to operate without PIM problems in this environment.

Where concealed antenna solutions fail PIM, the Lead Carrier will not agree to commission the DAS. In such circumstances, stakeholders will need to consider whether compromised visual aesthetics, or poor mobile network coverage for residents are priority for the project.

**Performance Required:**

Design RF coverage contours to achieve the performance levels contemplated in Section 3.4 to the following areas unless agreed otherwise:

- Inside Apartments
- Building Core/Resident-accessible Common Areas, Storage etc.
- Inside Lift Cars (travelling non-stop the entire lift-run - best efforts required but does need to include RF design contours)
- Basement Carparks
- Plant Rooms
- Fire Stairs (best efforts)

---

### 3.7.3 SERVICED APARTMENTS

Depending on the size and configuration, the design principles will be similar to Residential or Hotels.

Serviced apartments are often individually owned through strata subdivisions – or readily capable of being changed to this configuration in the future – therefore DAS cabling to serviced apartments must be individually isolatable in the manner described in Section 3.7.2.

**Performance Required:**

Design RF coverage contours to achieve the performance levels contemplated in Section 3.4 to the following areas unless agreed otherwise:

- Inside Apartments
- Building Core/Occupant-Accessible Common Areas, Storage etc.
- Inside Lift Cars (travelling non-stop the entire lift-run - best efforts required but does need to include RF design contours)
- Basement Carparks
- Plant Rooms
- Fire Stairs (best efforts)

---

#### 3.7.4 HOTELS

Where it is more cost-effective, branch cabling for antennas can be run through partition walls between hotel suites rather than through common areas as required for residential designs.

However, experience suggests that typically corridor mounted cabling and antennas will provide sufficient coverage to most hotel rooms.

**Performance Required:**

Design RF coverage contours to achieve the performance levels contemplated in Section 3.4 to the following areas unless agreed otherwise:

- Inside Hotel Rooms
- Occupant-Accessible Areas (corridors, restrooms, hotel facilities, shops)
- Back-of-house areas (accessible to staff or authorised personnel)
- Building Core
- Lobbies, Restaurants, Function Areas (potential for large people volumes)

- Inside Lift Cars (travelling non-stop the entire lift-run - best efforts required but does need to include RF design contours)
- Basement Carparks
- Plant Rooms
- Fire Stairs (best efforts)

---

### 3.7.5 COMMERCIAL OFFICE

Unless the floors are already partitioned, the design must have spare RF power to allow for future changes to floor layouts – such as subdivision of floors, addition of meeting rooms, offices etc. When no fitout information is available a margin of 5dB is acceptable.

#### **Performance Required**

Design RF coverage contours to achieve the performance levels contemplated in Section 3.4 to the following areas unless agreed otherwise:

- General Workplace Floor Areas
- Building Core (restrooms, kitchens, corridors, lift foyers, break areas)
- Inside Lift Cars (travelling non-stop the entire lift-run - best efforts required but does need to include RF design contours)
- Basement Carparks
- Plant Rooms
- Fire Stairs (best efforts)

---

### 3.7.6 SHOPPING CENTRE

Areas needing MIMO coverage should be targeted in consultation with the Lead Carrier.

#### **Performance Required:**

Design RF coverage contours to achieve the performance levels contemplated in Section 3.4 to the following areas unless agreed otherwise:

- General Public Accessible Areas (shops, food courts, walkways/promenades, entries etc.)
- Back-of-House Areas (storage, maintenance areas etc.)



- Building Core
- Inside Lift Cars (travelling non-stop the entire lift-run - best efforts required but does need to include RF design contours)
- Basement Carparks
- Plant Rooms
- Fire Stairs (best efforts)

---

### 3.7.7 CONVENTION CENTRES

To cater for sufficient performance and capacity, designs must consider MIMO. Additional requirement to consider maintenance factors and ensure design seeks to simplify access. Avoid splitting devices in hard-to-access areas such as high ceilings etc. The likely numbers of people attending functions in the various parts of the building will need to be considered.

#### **Performance Required:**

Design RF coverage contours to achieve the performance levels specified in Section 3.4 to the following areas unless agreed otherwise:

- General Public Accessible Areas (convention halls, food courts, restrooms, entries etc.)
- Back-of-House Areas (offices, storage, maintenance areas etc.)
- Inside Lift Cars (travelling non-stop the entire lift-run - best efforts required but does need to include RF design contours)
- Basement Carparks
- Plant Rooms
- Fire Stairs (best efforts)

---

### 3.7.8 STADIUMS

It is strongly recommended not to commence any works without working very closely with the Lead Carrier. Capacity, sectors and interaction with macro network are site specific and need to be treated carefully. MIMO will be considered mandatory for stadiums.

#### **Performance Required:**

Design RF coverage contours to achieve the performance levels contemplated in Section 3.4 to the following areas unless agreed otherwise:

- Stadium criteria will be defined by dominance relative to external mobile networks and will be advised by Lead Carrier
- Pitch/In-Field criteria will be defined by Lead Carrier
- Back-of-House Areas (offices, storage, maintenance areas etc.)
- Inside Lift Cars (travelling non-stop the entire lift-run - best efforts required but does need to include RF design contours)
- Back-of-House Areas (offices, storage, maintenance areas etc.)
- Basement Carparks
- Plant Rooms
- Fire Stairs (best efforts)

---

#### 3.7.9 AIRPORTS

MIMO will depend on the size of the airport, among other factors. Areas needing MIMO coverage should be targeted in consultation with the Lead Carrier. It will be important to determine with airport stakeholders what other areas must be addressed such as baggage areas etc.

##### **Performance Required:**

Design RF coverage contours to achieve the performance levels contemplated in Section 3.4 to the following areas unless agreed otherwise:

- General Public Accessible Areas
- Back-of-house areas (accessible to staff or authorised personnel)
- Inside Lift Cars (travelling non-stop the entire lift-run - best efforts required but does need to include RF design contours)
- Basement Carparks
- Plant Rooms
- Fire Stairs (best efforts)

---

#### 3.7.10 RAIL TUNNELS

MIMO will be considered mandatory for most metropolitan rail tunnels. Handover between sectors must be carefully considered for continuity of service. The size of sectors will also be a particular area of interest to ensure the carriers can provide adequate capacity.

**Performance Required:**

Design RF coverage contours to achieve the performance levels contemplated in Section 3.4 to the following areas unless agreed otherwise:

- Contiguous performance through the length of the tunnel (measured at centre of a train carriage filled to capacity with commuters)
- Underground Stations / Platforms
- Inside Lift Cars (travelling non-stop the entire lift-run - best efforts required but does need to include RF design contours)
- Emergency egress and back-of-house areas (accessible to staff or authorised personnel)
- Basement Carparks
- Plant and Equipment Rooms/shelters

---

### 3.7.11 MOTORWAY TUNNELS

**Performance Required:**

Design RF coverage contours to achieve the performance levels contemplated in Section 3.4 to the following areas unless agreed otherwise:

- Contiguous performance through the length of the tunnel (measured inside a typical motor vehicle)
- "Emergency egress and back-of-house areas (accessible to staff or authorised personnel)"
- Capacity must be designed to cater for network traffic peaks which arise due to delays caused by traffic incidents within the tunnels.
- Handover to and from external macro coverage areas immediately adjacent to the tunnel portals
- Plant and Equipment Rooms/shelters

---

### 3.7.12 HOSPITALS

Designers might also want to identify whether any particular machinery areas will be a problem for PIM due to noise.

Consideration should be given to installing the DAS infrastructure such that sterile areas can be isolated.

**Performance Required:**

Design RF coverage contours to achieve the performance levels contemplated in Section 3.4 to the following areas unless agreed otherwise:

- All General Areas (consulting/treatment rooms, emergency, wards, operating theatres, shops, cafeterias, walkways, waiting areas, entries etc.)
- Back-of-house areas (accessible to staff or authorised personnel)
- Building Core
- Inside Lift Cars (travelling non-stop the entire lift-run - best efforts required but does need to include RF design contours)
- Basement Carparks
- Plant Rooms
- Fire Stairs (best efforts)
- Public stairs

Need for coverage to Radiology and X-Ray areas to be discussed and agreed with the hospital.

Care is also required to ensure that EMI limits in Section 3.11 are not exceeded in locations with sensitive medical equipment.

### 3.8 PASSIVE DAS INTERCONNECT PORTS

The accepted method for combining signals onto a common passive DAS is by way of a Multi-Network Combiner (MNC). These combiners are generally available with four input ports, and four output ports. Each of the four outputs carries a composite signal which is a composite of all of the signals that appear at the input ports.

The MNC combines the signals from each of the Sharing Carriers, and then distributes these to the DAS segments.

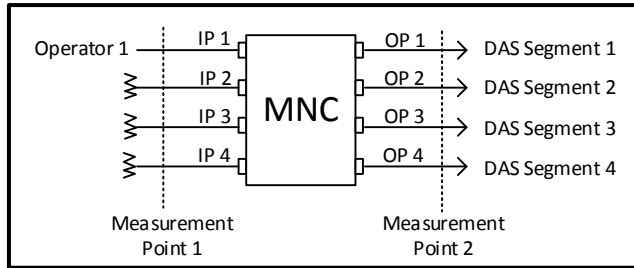

Figure 1 MNC Configuration Diagram

In consideration of the potential for passive intermodulation (PIM) products to cause interference in a DAS, each input port of the MNC shall have input powers according to Table 6 Maximum Input Power.

Specification	Value
Maximum Input RF Power per Port	100 watts (+50 dBm) composite
Maximum Power per RF carrier (700 – 2500 MHz)	10 watts (+40 dBm)
Maximum Power per RF carrier (> 2500 MHz)	20 watts (+43 dBm)

Table 6 Maximum Input Power

These levels must be used as the basis of the link power budget, maximum signal level and EME calculations.

### 3.9 ACTIVE DAS INTERCONNECT PORTS

The design must provide a duplex input port for each Sharing Carrier for each frequency band which is being deployed. The combined RF power level at the point of interconnect must not exceed the Active DAS equipment manufacturer’s specification.

### 3.10 EME DESIGN CONSTRAINTS

Under no circumstances should the combined power level from all transmitters cause the power density within 100mm of any antenna to exceed the ARPANSA General Public power flux density (“Maximum exposure levels to radio frequency fields – 3 kHz to 300 GHz”, Radiation Protection Series No. 3, Australian Radiation Protection and Nuclear Safety Agency.).

The maximum composite input power should not exceed 6 dB below the tested maximum input power itself (based on four (4) operators connecting to the DAS). For example, for an antenna having a 30 dBm EME limit, the maximum input per operator must not exceed 25 dBm.

The DAS must be designed using the most updated version of information available from the file entitled: “Recommended Maximum Input Power Levels for Category 1 IBC Antennas” which is located in the “RF Safety Compliance (Guidelines, Processes, Procedures)” section of the RFNSA.

Where a DAS designer cannot access this information, they must request the Lead Carrier to provide it.

The EME design should assume a worst case scenario where each of the Sharing Carriers is feeding 100 watts (50 dBm) composite into their port of the multi-network combiner, and with a maximum power of 20 watts (43 dBm) per individual RF carrier measured at the MNC.

In the case of an Active DAS (or DAS segment), the EME design must assume that all active devices connected to an antenna are operating at their maximum rated composite output power per frequency band.

### 3.11 ELECTROMAGNETIC COMPATIBILITY (EMC) DESIGN CONSTRAINT

Designers shall familiarize themselves with the environment in which the DAS will be installed, taking note of any potential EMC issues that may arise, or any local rules imposed on the use of radio transmitters. As a guide they shall ensure the field strength levels in Table 7 Electromagnetic Interference (EMI) Limits are not exceeded at the equipment specified.

Location/Environment	Equipment Type	<i>Field strength limit</i>
<b>Hospitals</b>	Critical care medical devices	<b>1 V/m rms</b>
<b>Institutions for the Hearing Impaired</b>		<b>1 V/m rms</b>
<b>General Domestic and Business Equipment</b>	Location of domestic electrical equipment and appliances, e.g. radio & television receivers, IT equipment.	<b>3 V/m rms</b>

Location/Environment	Equipment Type	Field strength limit
Co-located Base station	Other Base station equipment	3 V/m rms
<i>Explosives and Fuel</i>	<i>Electro explosive devices – quarries, blasting sites. Military. Petroleum or aviation gas fuel sites.</i>	9 V/m rms

Table 7 Electromagnetic Interference (EMI) Limits

The design of the DAS should take into account the following EMC standards.

**AS/NZS 61000.6.1:2006:** - Electromagnetic compatibility (EMC) - Generic standards - Immunity for residential, commercial and light-industrial environments. Replaces **AS/NZS 4252.1:1994**.

**BS 6656:2002:** - Guide to prevention of inadvertent ignition of flammable atmospheres by radio-frequency radiation. Replaces British Standard **BS6656:1991**.

**PD CLC/TR 50427:2004:** - Assessment of inadvertent ignition of flammable atmospheres by radio-frequency radiation. Replaces British Standard **BS6657:1991**

As a guide, Table 8 indicates the distances from an antenna that the 1, 3 and 9 V/m electric field strength limits are reached (to within 0.1 m). Note that, for a given EIRP, the electric field strength at a given distance is independent of frequency and varies linearly with distance.

Input Power to Antenna (dBm)	Antenna Gain (dBi)	Distance (m)	Electric field strength (V/m)
+23	3	3.5	0.99
+23	3	1.2	2.89
+23	3	0.4	8.68
+23	6	4.9	1.00

Input Power to Antenna (dBm)	Antenna Gain (dBi)	Distance (m)	Electric field strength (V/m)
+23	6	1.7	2.89
+23	6	0.6	8.18
+23	9	7.0	0.99
+23	9	2.3	3.01
+23	9	0.8	8.66
+23	12	9.8	1.00
+23	12	3.3	2.97
+23	12	1.1	8.90

Table 8 Distance from antenna for E field limits

### 3.12 MAXIMUM SIGNAL RECEIVED BY USER EQUIPMENT (UE)

The maximum signal levels received by a UE (e.g. a mobile phone) situated as close as possible to any antenna while being 1.5m above floor level shall be in accordance with the table below (3GPP TS25.101 Clause 7.4 for WCDMA and 3GPP TS36.101 Clause 7.4 for LTE).

Technology	Maximum received power
<b>WCDMA</b>	<b>-25 dBm/3.84 MHz</b>
<b>LTE</b>	<b>-25 dBm/channel bandwidth</b>

Table 9 Maximum Received Levels at MS/UE

Note that for a passive DAS the minimum path loss is determined by the maximum allowable levels at the BTS receiver inputs as in Section 3.13 below.

### 3.13 MINIMUM ALLOWABLE PATH LOSS

#### 3.13.1 PASSIVE DAS

The DAS design must consider the circumstances where an uncoordinated UE (i.e. not being served by any of the RF carriers present on the DAS) is operating on an adjacent channel, or a



controlled UE is operating on the wanted channel at minimum transmit power, may lead to the base station receiver being overloaded.

These levels are specified in the 3GPP specifications (3GPP TS25.104 for UMTS and TS36.104 for LTE).

Table 10 shows the minimum allowable path loss – which in the case of a passive DAS refers to the coupling loss from a UE being operated at a nominal 1.5m above floor height, to the carrier base station input. (Note: this value includes the losses in the MNC and the antenna distribution network)

Technology	UE Tx Power	Maximum Carrier Base Station Received Power	Minimum Path Loss	
WCDMA	+24 dBm	-52 dBm/3.84 MHz	76 dB	<i>Adj.- channel</i>
	-50 dBm	-73 dBm/3.84 MHz		<i>Co-channel</i>
LTE	+23 dBm	-52 dBm/occ BW	75 dB	<i>Adj. - channel</i>

Table 10 Minimum allowable path loss

### 3.13.2 ACTIVE DAS

The design must ensure that the Maximum BTS received power values of Table 9 are complied with.

Ensure that the maximum uplink input signal levels at the remote units do not exceed the manufacturer’s ratings.

## 3.14 RF PROPAGATION MODEL

This document does not specify a propagation model as it is a responsibility of the DAS design vendor to ensure that sufficient margins are provided, so that the minimum signal levels specified in this document are delivered by the designed system once it is in operation.

## 3.15 MEASURED PERFORMANCE OF INSTALLED DAS

In addition to the coverage, power and loss specifications above, a passive DAS shall meet the following performance requirements.

---

### 3.15.1 RETURN LOSS

The return loss of each passive DAS segment connecting to a multi-network combiner shall be  $\geq 16$  dB over the operating frequency bands. Where a DAS segment is comprised of multiple branches connecting to a DAS segment, the connection points to the branch must each also individually comply with the above performance requirement.

In the case of an Active system the return loss at the point of interconnect closest to the remote unit shall be greater than 16 dB.

---

### 3.15.2 PASSIVE INTERMODULATION (PIM)

The third-order passive intermodulation performance of each passive DAS segment connecting to a multi-network combiner shall be  $\leq -140$  dBc with 2 x 43 dBm carriers. The test must be performed with the antennas connected to the DAS segment under test and ensure EME precautions are followed.

The DAS must conform to above standards for frequencies in both low band and high band. The corresponding 3GPP bands are as follows:

- Low Band = Band 5, 8 or 28
- High Band = Band 1, 3 or 7

For the purpose of PIM performance requirements on an Active DAS (with an output power per band  $> 5$  watts), each active remote unit will be viewed as if it is a “multi-network combiner” with the above passive DAS testing.

Where an Active DAS with an output power  $\leq 5$  watts, the passive intermodulation performance of each passive segment connecting to the remote shall be  $\leq -140$  dBc with 2 x 33 dBm carriers in both low band and high band as above.

For further details on PIM refer to Section 5.0.

---

### 3.15.3 FREQUENCY RESPONSE

The frequency response of the passive DAS shall be within 1 dB across each of the operating frequency bands listed in Table 1.

---

### 3.15.4 PROPAGATION DELAY

The maximum propagation delay of the DAS shall be less than 10  $\mu$ S.

---

#### 3.15.5 SYSTEM UPLINK NOISE PERFORMANCE

The uplink noise rise on any system must not exceed 3 dB as measured on the carrier base station receiver under normal traffic conditions.

#### 3.16 CABLE AND COMPONENT LABELLING

Labelling of DAS cable and components must be completed in accordance with the requirements of the Lead Carrier. If the Lead Carrier is unknown during the physical installation process, as a minimum, all installed cable and components must be labelled as follows:

- *Horizontal* runs of cable shall be labelled with a sticker at intervals of approximately 6 metres.
- *Vertical* runs of cable, such as in risers, stickers shall be placed at approximately 1.8 metres above floor level on every floor.

Labelling stickers shall also be attached on or close to each component. Labelling stickers must not be placed on the radiating element of the antenna or on the component identification plate, however labelling stickers shall also be placed on radiating cable in accordance with the spacing intervals indicated above.

All feeders must be identified at both feeder opening points with a label containing a concise identification code uniquely identifying each cable and cross-referenced to the system drawing. Identification labels shall be provided by the contractor.

#### 3.17 APPROVED MATERIAL LIST

The DAS designer must verify the suitability of all materials and equipment proposed to be used on the DAS with the Lead Carrier prior to incorporation in the DAS design and before the placement of any material purchase orders.

This step is very important. Material and equipment selection not only contributes to the long term reliable performance of the DAS, but will ensure the Lead Carrier is capable of providing the necessary ongoing management, maintenance and support.

Lead Carriers will maintain (and provide upon request) a list of approved equipment that is to be used for a DAS with the relevant Lead Carrier.

The use of high quality RF connectors is mandatory. Each of the mobile carriers has a published approved material list which must be adhered to.

Cables shall meet the requirements of relevant building codes, fire authorities and building owners/managers in respect of fire retardant and smoke emission properties. Provided the cables conform to the Lead Carrier requirements of this section and the component requirements detailed in Section 3.18, there are no specific requirements for general office areas, however some buildings may require particular cable specifications.

If an existing DAS installation has fire retardant or low smoke emission cables, any subsequent design, extension or modification must continue to specify cables with equivalent properties for that DAS.

### 3.18 DAS COMPONENT SPECIFICATIONS

Each individual component of the DAS must meet or exceed the performance characteristics detailed below for all operating frequency bands listed in Table 1 of Section 2.5.

#### 3.18.1 CHARACTERISTIC IMPEDANCE

RF circuit impedance of all components shall be 50 ohm unbalanced.

#### 3.18.2 COMPONENT RETURN LOSS

All passive components must be rated by the manufacturer to have better than 16 dB return loss over the operating frequency bands listed in Table 1.

#### 3.18.3 COMPONENT PIM PERFORMANCE

The third-order passive intermodulation (PIM) performance for each individual component in the DAS must be as indicated in Table 11 Passive Component PIM Specification.

The Test Condition detailed in this table requires performance specification conformance for frequencies in both a low band and a high band. The corresponding 3GPP bands are as follows:

- Low Band = Band 5, 8 or 28
- High Band = Band 1, 3 or 7

Component Description	Third-order passive intermodulation performance	Test condition
Splitters and Couplers	≤ -150 dBc	2 x 43 dBm carriers

Low power (<5 watt) 50 ohm terminations	$\leq -140$ dBc	2 x 33 dBm carriers
High power ( $\geq 5$ watt) 50 ohm terminations	$\leq -150$ dBc	2 x 43 dBm carriers

Table 11 Passive Component PIM Specification

### 3.18.4 COAXIAL CONNECTOR TYPES

Table 12 indicates the types of coaxial connector which may be used on a DAS and where they can be deployed. All coaxial connectors must be checked for compliance with the relevant standards.

DIN connectors must be installed and tightened in accordance with their applicable standards.

Connector Type	DAS Location	Standard
7-16	All Ports	DIN 47223
4.3-10	All Ports	IEC 61169-54
N-Type	Not Allowed	Not Allowed
Inter-series coaxial adapters	Not Allowed	Not Allowed
Other	Subject to Lead Carrier direction	To Be Determined

Table 12 Permitted Coaxial Connector Types

### 3.18.5 COAXIAL CABLES

Only coaxial cables with solid outer conductors may be used for multiband signal carriage.

Patch cables with solid outer must be used for interconnections between the base station equipment and any filters, splitters and combiners, unless specifically agreed by the lead operator. The braided cables used should then only carry single band signals and be approved by the lead operator. All cables, with either solid or braided outer conductors shall meet the minimum performance parameters below.

Factory assembled feeder patch cables shall be specified with the following minimum performance parameters:

- **Return Loss:**  $\geq 26$  dB over the operating frequency ranges listed in Table 1.
- **Intermodulation performance:** Any third order product must be  $\leq -150$  dBc with 2x 43 dBm carriers under both static and dynamic conditions for the operating frequency ranges listed in Table 1.
- **Connectors:** DIN 7-16 or 4.3-10, as required (refer Section 3.18.4)
- **Joiners and inter-series adapters** are not to be used in any circumstances.

---

#### 3.18.6 CABLES WITH BRAID, FOIL OR FOIL/BRAID SCREENING

Cables of this type (for example LMR400, RG214 etc.) have been found to have poor intermodulation performance regardless of the quality of the connector terminations, and must not be used.

---

#### 3.18.7 ANTENNAS

Each of the mobile carriers has a published approved material list which must be adhered to.

---

#### 3.18.8 GPS ANTENNAS

Carrier base station equipment now increasingly requires GPS synchronisation. This requires a direct cable path to be identified and reserved for the carriers from the equipment room to a viable GPS antenna position outside the building.

The DAS installer must identify an external location for carriers to install sky-facing GPS antennas with clear line-of-site above the horizon in order to receive signal from GPS constellations.

Ideally the GPS antenna should be located in an open space with unobstructed 180° view of the sky as indicated in Figure 2. Where that is not possible, a location with visibility of no less than 90° of sky must be selected as indicated in Figure 3.

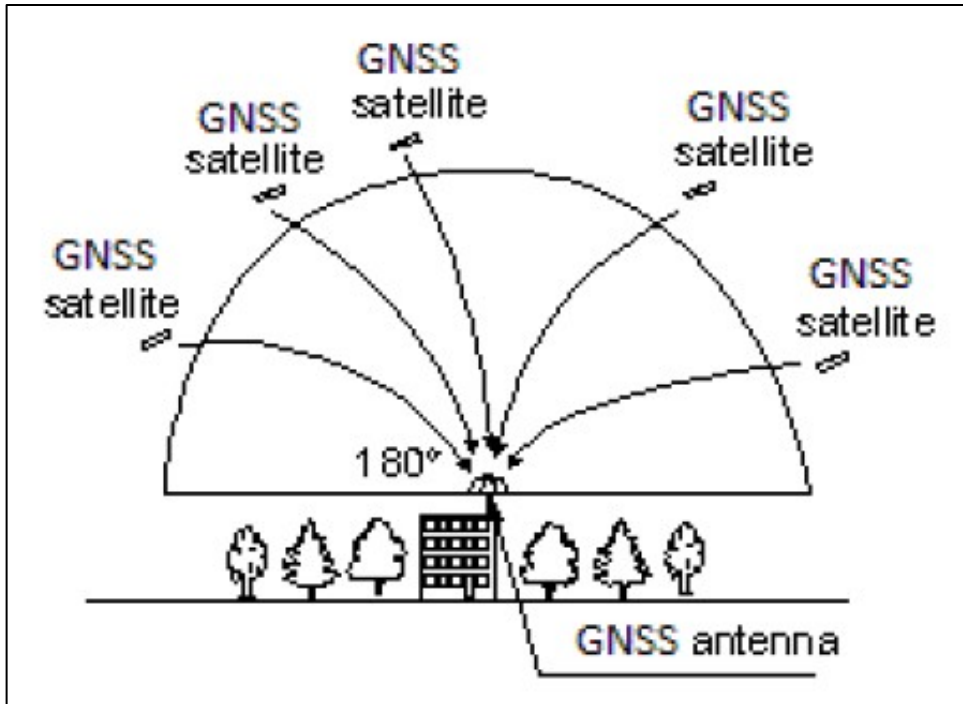

Figure 2 Ideal GPS Antenna View of Sky

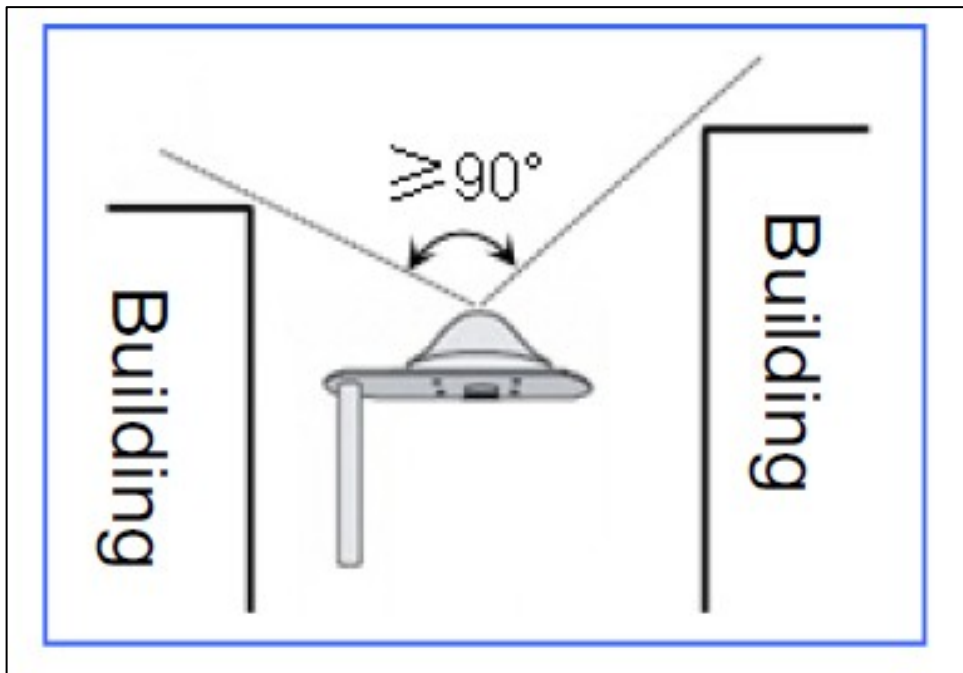

Figure 3 Minimum GPS Antenna View of Sky

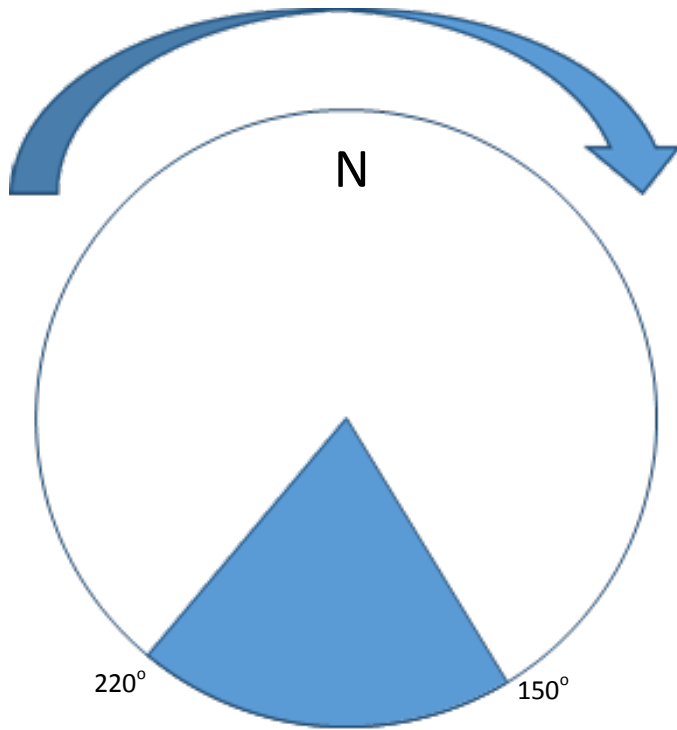

Figure 4 GPS Line of Site - Horizontal Plane

The antenna location should not be obstructed in the horizontal plane (azimuth) between 220 degrees and 150 degrees looking clockwise through true north as per Figure 4.

In a DAS environment, multiple GPS antennas will be installed at the site and there must be allowance for at least 0.5m separation in the horizontal plane. When allocating space, the GPS antenna:-

- Must not be positioned close to high voltage power cables
- Must not be positioned in the main lobe or exclusion field radiation areas of mobile RF panel antennas, microwave antennas or any other type of EME hazard.

A minimum 1 x GPS antenna is required per operator. The GPS cable is to be installed in consultation with the operators. The DAS installer must also identify a cable path from the carrier base station equipment to the GPS antennas. In some cases it may be more appropriate for the DAS contractor to install cables for GPS antennas during construction works to minimise disruption. Where applicable, the carriers will supply cables to the DAS contractor for this purpose.



There must be a separate and dedicated GPS antenna for each carrier and it is important to recognise that maximum feeder length can become a limiting factor for GPS antenna positioning. The Lead carrier must be engaged to advise on GPS design criteria and requirements.

GPS antenna feeds cannot be combined because the GPS solution uses active antennas which are based on particular carrier hardware and capacity requirements.

---

### 3.18.9 CABLES THAT SUPPORT REMOTE OR ACTIVE EQUIPMENT

In an Active DAS, fibre optic cable or twisted pair structured cabling is used to distribute the signals to different areas where long runs of RF Cable may not be practical.

If an Active system can support either optical fibre or structured cabling, optical fibre must be used unless the Lead Carrier agrees otherwise.

---

#### 3.18.9.1 OPTICAL FIBRE CABLING

Optical fibre cabling to support Active DAS equipment must be supplied and installed to manufacturer specifications for the Active DAS equipment.

All fibres supporting Active equipment must be physically separate and also clearly distinguishable from any other fibre which may be installed within or throughout the premises. To avoid any risk of service disruption between different types of users (carriers for a DAS and building operators/occupants for other purposes), the use of base-building fibre to support Active DAS equipment is not permitted.

Optical fibre cabling comprises several components; the main fibre cables comprising multiple fibres in a sheath, pigtails spliced to the main fibres at each end and terminated into a patch panel and finally patch leads at each end. In some cases there may also be intermediate splice points where smaller cables are spliced into larger cables.

On smaller installations, the use of individual prefabricated cables may be preferable to avoid the need for splicing onsite. Where splicing is used, all fibres must be spliced using a fusion splicing machine which is approved by the Lead Carrier. At joint locations, the average two way splice loss for jointed fibres shall not exceed 0.10 dB at 1550 nm and 1625nm.

---

#### 3.18.9.2 STRUCTURED CABLING

Where an Active system requires structured cabling, the cable quality standard of twisted pair structured cable must be equivalent or better than the manufacturer specifications required for

the particular Active equipment which is being connected to that cabling. Shielded structured cabling is preferred.

The distances must not exceed the maximum cable length for the given standard of structured cable being used.

## 4 DELIVERABLES

### 4.1 DOCUMENTATION

#### 4.1.1 SUBMISSION OF DOCUMENTS

The DAS contractor must provide the Lead Carrier with all preliminary/detailed design documentation and turn-key as-built installation documentation.

Submission of DAS information to the Lead Carrier must be through Soft copies of all drawings, documents and test results. Due to large file sizes, the most common method of submission is currently web-based file servers (e.g. Dropbox, OneDrive, Box etc.) which are accessible by the relevant Lead Carrier. The Lead Carrier will retrieve the information and permanently store the information onto the Lead Carrier's record keeping systems.

Where storage media such as CD/DVD are used, these must be properly labelled. The use of USB memory sticks or SD Cards may be used where agreed with the Lead Carrier. Directly emailing smaller files (generally <10 Mb) may be acceptable, however most carrier corporate email servers reject larger files.

#### 4.1.2 COPYRIGHT AND OWNERSHIP OF DAS DESIGN INFORMATION

The Lead Carrier assumes ownership and responsibility of the DAS and therefore must be granted unfettered title and copyright of any design material pertaining the DAS from the authors of that material.

#### 4.1.3 FILE TYPES AND DOCUMENT SECURITY

All files must be submitted completely unlocked in their original software production form so they are editable by the Lead Carrier for future modifications to the DAS. For example, the power budget spreadsheets can be updated with the addition of extra technologies or channels in the future using the original MS Excel file. The Carriers must share editable link but this does not include specific IP. Carriers will also share Power budgets.

Text or numeric documents shall be provided using the latest suite of Microsoft Office (i.e. MS Word or MS Excel). Submission of any other file formats for these types of documents must be specifically agreed with the Lead Carrier.

All photos, digital images or screenshots are to be delivered in JPEG (\*.jpg) or Bitmap (\*.bmp) format to a minimum resolution of 1024 x 768 pixels (higher resolutions are preferred).

If a DAS has been designed in iBwave™ those format files must be provided.

Where CAD has been used for design, the drawings must also be supplied in AutoCAD format and be made available to the Lead Carrier. In cases where CAD files are not available, documentation shall be provided in high resolution PDF.

Any other supplied documents – such as component specifications or scanned base-building drawings etc. must be provided in high resolution Portable Document Format (\*.pdf).

#### 4.2 PRELIMINARY DAS DESIGN DOCUMENTATION FOR LEAD CARRIER REVIEW

The DAS designer must submit preliminary DAS design documentation with any relevant related information to the Lead Carrier for confirmation of design acceptability prior to progression to detailed design. The preliminary documentation must address the following:

1. Location and physical size (sq. m) of the building.
2. Number of levels in the building and which levels are being serviced by the DAS (i.e. a clear indication of the Target Coverage Areas).
3. Forecast occupancy information
  - a. Maximum number of people expected to be served by the DAS at peak time.
  - b. Breakdown of tenants (if applicable and available).
  - c. Any known high capacity service requirements (e.g. tenants want wireless offices).
4. Type of DAS proposed
  - a. Passive, Active or Hybrid.
  - b. Technologies proposed to be catered upfront (particularly for Active systems)
  - c. Number of RF carriers the link budget has been designed for.
5. A general description of the proposed concept design based on Section 2.0;
6. Antenna layout floor plans;
7. A system schematic diagram;

8. A high level sector design (visually identifiable with different colours for each sector).
9. Link power budget calculations for a single RF carrier in each of the frequency bands/technologies identified in Sections 2.5 and 2.6 of this document.
10. Calculation to show the composite power calculated at each antenna port to demonstrate compliance with Section 3.10 and 3.11.
11. Coverage predictions demonstrating that RF levels are in accordance with Section 3.4.
12. Bill of materials (excluding installation materials).

#### 4.3 DETAILED DAS DESIGN DOCUMENTATION FOR LEAD CARRIER APPROVAL

After the preliminary design documentation has been reviewed and approved by the Lead Carrier, the DAS designer must provide further detailed design documentation expanding on the approved preliminary design.

The Lead Carrier will review the detailed documentation and provide an approval confirming the acceptability of the DAS design prior to any installation works commencing. The following information must be submitted for the Lead Carrier to provide approval of the detailed DAS design.

- 1) Design survey results:
  - a. Existing coverage levels, conducted on street level to evaluate handover requirement.
  - b. Existing coverage levels, conducted on a medium floor and a high floor to evaluate interference; these surveys should be conducted and plotted as a snail trail overlaid on floor plans. (RSCP and Ec/Io plots should both be collected for WCDMA, and RSRP and SINR for LTE, for the bands the carriers are connecting to upfront).
  - c. Best serving cell
- 2) Clearly demonstrate the DAS can achieve the performance criteria in Table 4 RF Signal, Dominance and Quality Performance Levels for DAS for all Target Coverage Areas to ensure satisfactory data throughput, capacity and performance.
- 3) Identify the proposed DAS coverage transition areas with the external mobile network.

- 4) System description.
- 5) System schematic diagram.
- 6) Backbone distribution description.
- 7) A high level sector design (visually identifiable with different colours for each sector).
- 8) Equipment location and room details including access details, layout diagram/schematic showing BTS positions.
- 9) Actual photos of the proposed equipment room (if present).
- 10) Calculations to demonstrate:
  - a. The RF levels predicted are in accordance with Section 3.4.
  - b. Composite power at each antenna port complies with Sections 3.10 and 3.11;
- 11) Prediction printouts. As a minimum for coverage level and quality. i.e. iBwave plots
- 12) Manufacturer's specification for all relevant equipment and material (power splitters, directional couplers, antennas, standard feeder cables, radiating coaxial cables, etc.).
- 13) Bill of materials (excluding installation materials)
- 14) Authority from the lead carrier for any Category 1 antenna where the power inserted will exceed the maximum composite power as stipulated in Section 3.10.
- 15) For Active systems – information about the DAS alarming/remote module which the Lead Carrier will be connecting to. Any specific items that will be required from the Lead Carrier to facilitate connection to the DAS alarming/remote module.

#### 4.4 FOR CONSTRUCTION INSTALLATION DOCUMENTATION

These details are a combination of generic installation practice and fabrication drawings and will also include structural engineering and details for unique installation scenarios at a site. For-construction drawings must provide installation related information, sufficient for actual installation works:

- 1) Instructions for installation of the design:
  - i) antenna mounting instructions;
  - ii) floor cable mounting instructions;
  - iii) communications riser cabling instructions;

- iv) equipment room cabling instructions;
  - v) cable handling instructions;
  - vi) cable labelling instructions.
- 2) Drawing:
- i) DAS system schematic;
  - ii) floor layout for every floor;
- 3) Floor layout drawings
- i) showing the cable runs and antenna placement on each floor,
  - ii) sufficient detail and landmarks so a person unfamiliar with the site can trace out the proposed cable run and show the proposed positions of antennae and other components (couplers, splitters, etc.) without needing to remove the ceiling tiles.
  - iii) Where applicable, the floor plan should also show preferred cable entry/exit points.
- 4) Drawings must be prepared to scale in accordance with Australia Standards and recommendations as follows:
- i) Drawing title, boundary, etc.
  - ii) Structural walls, lift cores, permanent brick or block partition walls, etc.
  - iii) Semi-permanent office partition walls (of plasterboard, glass, etc.) of full height to ceiling level. Other partitions, such as workstation partitions, may be omitted.
  - iv) Structural details and existing riser details, such as existing cable ladders, large pipes, etc., which are significant;
  - v) proposed cable, component, and equipment design details
  - vi) proposed cable, component, and equipment label designation
  - vii) Installation details for non-standard cable and component installation.
  - viii) backbone distribution layout;
- 5) Bill of material (including installation materials).
- 6) All aspects of civil engineering design work (if required) including the following:
- i) the structural design of the antenna support structures; and

- ii) any other structural calculations or designs.
- 7) Specifications and instructions relevant to cabling, wiring and termination work of the RF feeders, optical fibre cables, power wiring, and earth connections including:
  - i) assembling of parts;
  - ii) fitting of connectors;
  - iii) Any other information that may fall within this category.
- 8) Specification of AC power outlets for all AC powered equipment specified in DAS.
- 9) Security materials and installation specifications and details in accordance with requirements of Section 8.11
- 10) Design and specification of the protective earth systems including lightning finials on the antenna support structures for all externally installed antennas;
- 11) Testing and commissioning specification and procedure of the Distributed Antenna System, and data recording sheets (refer to Section 8.0 Carrier Equipment & Accommodation Requirements), including:
  - i) RF sweeps;
  - ii) RF power measured at the designated test points;
  - iii) calculated line loss with regard to the reference point;
  - iv) passive intermodulation testing;
  - v) all alarm indications of the supervisory system (if applicable) to demonstrate that they are operational to the manufacturer's specification.

#### 4.5 HANDOVER DOCUMENTATION

The following information must be submitted in a final package to the Lead Carrier for acceptance and handover of the DAS to the Lead Carrier:

- 1) As-built versions of the information submitted in Section 4.3 above. (These drawings should not materially deviate from the proposal submitted to and approved by the Carrier in Section 4.3 above.)
- 2) Test results for all installed components as detailed in Section 7.1 below.
- 3) For Active systems, all configuration information, parameter settings etc.

- 4) Location of DAS equipment spares:
  - i) Instructions how to access spares if they are held onsite
  - ii) Otherwise the Lead Carrier depot location where any spares were physically delivered to the Lead Carrier.
- 5) Any other relevant information required for the Lead Carrier to assume responsibility to successfully operate and maintain the DAS.

## 5 PASSIVE INTERMODULATION (PIM)

### 5.1 WHAT IS PASSIVE INTERMODULATION (PIM)?

Passive Intermodulation (PIM) is a form of intermodulation distortion that occurs in components such as cables, connectors and antennas. However, when these non-linear, passive components are subjected to the RF power levels found in cellular systems, they behave like a mixer, generating new frequencies that are mathematical combinations of the downlink frequencies present at the site.

PIM signals that fall in an operator's uplink band can elevate the noise floor, resulting in higher dropped call rates, higher access failures and lower data transmission rates.

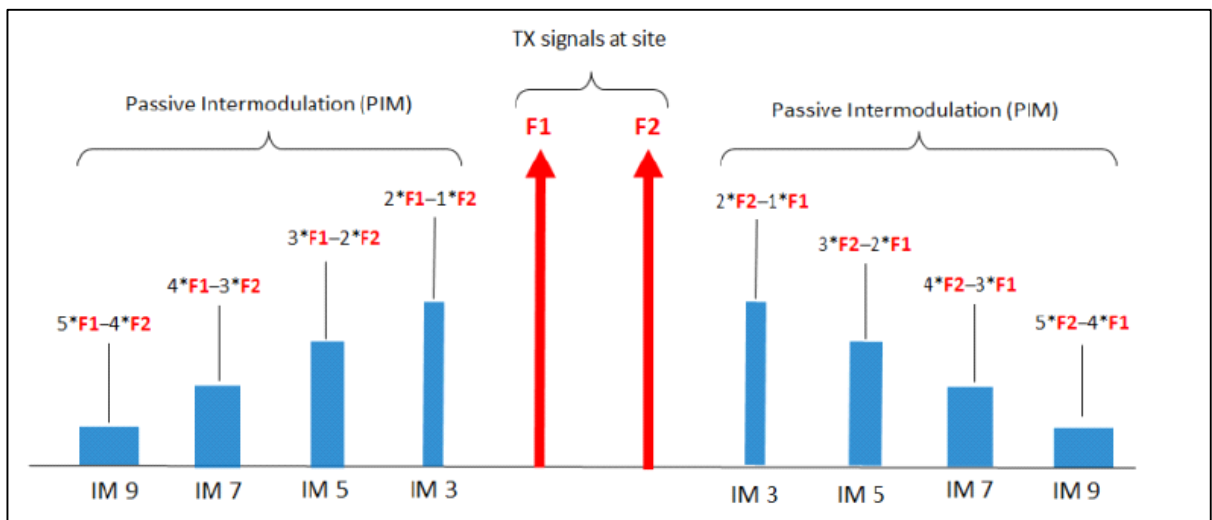

Figure 5 Passive Intermodulation (PIM) Products Produced by Two Signals

When referring to PIM products, the sum of the multipliers ( $n + m$ ) is called the product order, so if  $m$  is 2 and  $n$  is 1, the result is referred to as a third-order product. Generally, lower order intermodulation products (IM3, IM5) have higher magnitude than higher order intermodulation



products (IM7, IM9, IM11, etc.). If the downlink frequencies in use at a site are able to combine in such a way that low order IM products fall in an operator’s uplink band, PIM interference will be likely. This is not to say that higher order intermodulation products can be ignored. Depending on the degree of non-linearity and the RF power levels in use at a site, even high order IM products may be strong enough to impact site performance.

It is important to understand there is no relationship between Return Loss and PIM. It is possible to have good Return Loss and poor PIM, or, good PIM and poor Return Loss.

PIM is a bigger issue today than it used to be within DAS’s because new generation systems introduce better Rx technology & higher capacity through improved radio sensitivity. These generational performance improvements come at the expense of much greater equipment sensitivity. Consequently, DAS systems which now support LTE require more stringent test levels, due to the lower resource block sensitivity level, compared to other air interfaces.

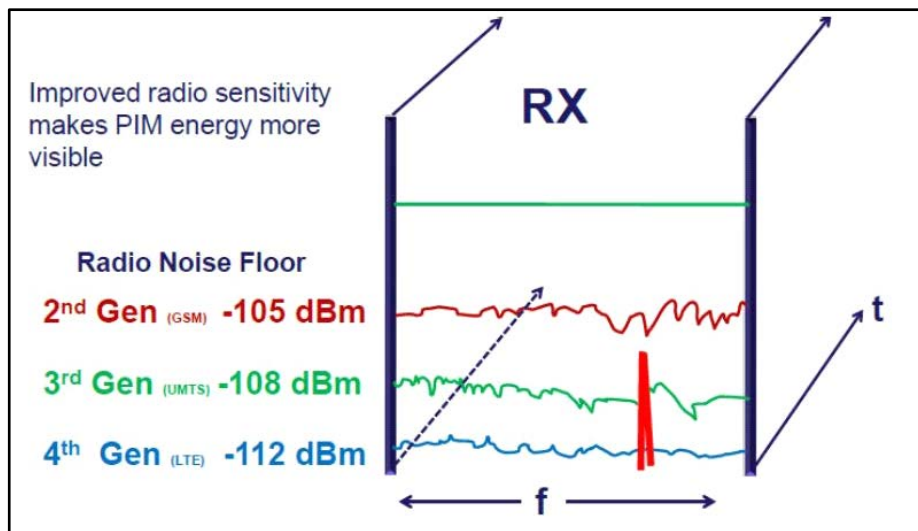

Figure 6 Noise Floor Tolerances between Communications Generations

## 5.2 WHAT ISSUES DOES IT CAUSE TO A DAS?

Noise and interference on the network inhibits proper use of the system. Interference due to PIM presents as an elevated noise floor on a cellular base station. Whilst this noise cannot always be “heard” by end users, the sensitivity of the base station receiver is adversely impacted with the consequences of reduced coverage, increased call drops and decreased data throughput.

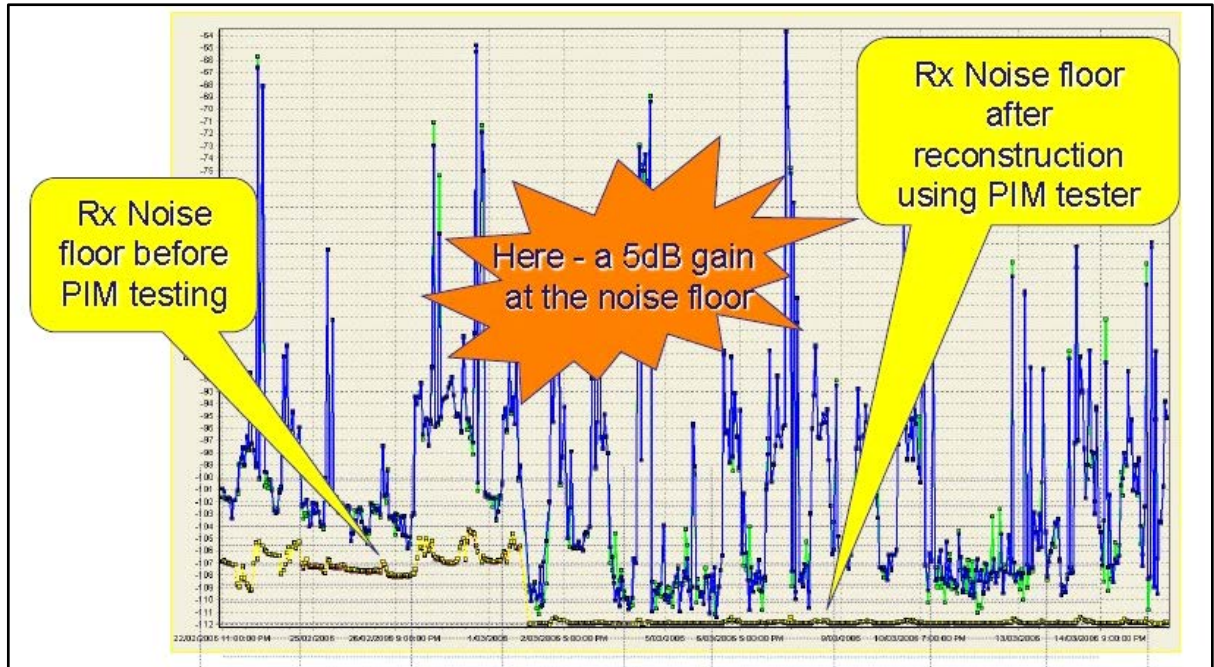

Figure 7 Poor PIM Performance on Base Station Receiver

PIM interference causes poor quality of service experience for users on the network and also generates negative perceptions about carrier networks performance and coverage.

Fault-finding the source of PIM becomes much more complicated when a DAS is operational and supporting customer traffic since building works and fit-outs are completed by the time a DAS gets commissioned. The process of fault-finding and repair also takes much longer because there are physical access limitations to areas which have been sealed/closed upon completion of construction fit-outs and also simply to find suitable timeslots to undertake the repairs when a building/DAS may be quieter.

From a carrier perspective, once the DAS is accepted and treated as an active and operational network element, the internal procedures and stakeholder management processes (internal and also for other connected carriers) for any proposed works must be managed in accordance with standard national-level operational processes the carriers each use.

### 5.3 HOW DO PIM PROBLEMS TYPICALLY ARISE?

The main causes of PIM are:

- I. poor quality components;
- II. poor workmanship; and

- III. inappropriate placement of antennas
- IV. Environmental causes from reflective objects near the antennas (generally within the roof space, like AC ducting)

The subsections below outline some further information on these topics.

Since the amplitude the PIM products obeys a non-linear characteristic, PIM products become more prevalent as the power levels increase. These types of PIM issues typically arise when the DAS is commissioned and begins to take more traffic – after handover.

Consequently the carriers require PIM testing to emulate the characteristics of a DAS which is operating at high power. These “stress tests” are conducted to confirm the DAS will be capable of supporting customers when the DAS is operating all potential carrier equipment in a high traffic operating environment.

---

#### 5.3.1 POOR QUALITY COMPONENTS

Inevitably, efforts to reduce cost through sourcing of alternate components leads to problems as a consequence of the materials which are used in component manufacture. Thinner material coatings or alloys using greater ferromagnetic content are typically attributed to increased difficulties with PIM. Furthermore these cheaper components are often more susceptible to degradation due to corrosion and oxidation (diode effect) and less able to tolerate the regular mechanical stresses associated with physical connection and disconnection over long periods of time.

---

#### 5.3.2 POOR WORKMANSHIP

Poor workmanship often arises with the use of persons who are not appropriately trained in carrier- grade RF cabling and installation requirements. Although an electrician may know how to run and terminate a telephone line or LAN cable, and possibly even splice an optical fibre, the specific PIM sensitivities associated with properly installing and terminating RF cabling are often not fully appreciated until the system fails a PIM test.

---

#### 5.3.3 INAPPROPRIATE PLACEMENT OF ANTENNAS

The small, low gain antennas normally used in DAS construction tend to illuminate external PIM sources near the antenna. These PIM sources are often behind the antenna, making them difficult to locate. Optimal antenna locations may be determined by PIM testing the antenna at its design location to evaluate external PIM sources. Moving the antenna within a few meters of

the design location typically will have little impact on coverage, but may have a significant impact on PIM results. Small movements of the antenna away from the primary PIM source – usually within a 1m diameter circle – resolves most external PIM problems while maintaining desired coverage.

#### 5.4 RECOMMENDATIONS TO MINIMISE PIM

PIM can be generated anywhere in the RF path. The RF path includes not only the antenna feed system but also includes the antenna itself, as well as objects excited by the antenna. Since RF currents are strongest inside the coaxial cables and physically close to the antenna radiating aperture, non-linear junctions or materials in these locations are more likely to generate harmful PIM. As the RF currents decrease with distance from the RF path, the PIM levels will decrease according to a non-linear characteristic and will have less impact on the wider system.

The following list provides guidelines for minimising PIM in DAS installations:

- Antennas inside ceiling cavities or within cluttered environments will lead to reduced coverage and will be more prone to PIM.
- Avoid placing antennas near exit lights, door openers, LAN cables or other equipment which emits electrical interference.
- Use factory terminated and PIM certified RF jumper cables where possible
- Higher quality components made from high quality materials will not experience corrosion or oxidation (diode effect), whereas cheaper quality materials will.
- Visually inspect RF connectors & RF cables before assembly to remove all metal flakes
- Verify that RF mating surfaces are clean and free of mechanical damage prior to assembly
- Wipe mating surfaces with a lint-free wipe, moistened with alcohol to remove dirt & oils
- Face coaxial cables downward while cutting so that any metal flakes produced fall out rather than into the coaxial cable
- Always use sharp cutting tools when preparing the ends of coaxial cables
- Use the correct cable preparation tools for the type and size coaxial cable you are working with
- Remove any metal burs from the cut edges of coaxial cables prior to connector attachment

- Prevent foam dielectric material from getting trapped between metal contacting surfaces
- Remove all adhesive residue from the mating region of the coaxial cable centre conductor
- Properly align RF connectors prior to assembly to prevent damage to mating surfaces
- Apply the manufacturer’s specified torque to all mated pairs of RF connectors.
- Do not over-torque RF connectors as this may cause damage to contacting surfaces
- Prevent excessive vibration and shock to RF components when transporting them to the site
- Leave protective caps on RF connectors until you are ready to attach the mating cable
- Position Antennas to avoid proximity to cable trays, vent pipes, air conditioning units, metal flashing, etc.
- Avoid loose metal objects (mounting hardware, metal chains, etc.) anywhere within 500mm of antennas

During construction, care must be taken to avoid mechanical stresses on RF connections so they do not create PIM sources over time. Proper mounting of components to a support structure and the use of stress relief in the cabling will assist in long term PIM performance.

Figure 8 indicates an initial and improved construction of a section of a MIMO RF path. The initial construction had components mounted by cable ties to plasterboard anchors, had no stress relieve and had poor tool access. Testing was difficult and the plasterboard anchors were not strong enough to properly secure the components and cables when assembly torque was applied.

Consequently the anchors pulled out, leaving components hanging by the RF cables, introducing stresses to the RF connections. PIM became erratic over time.

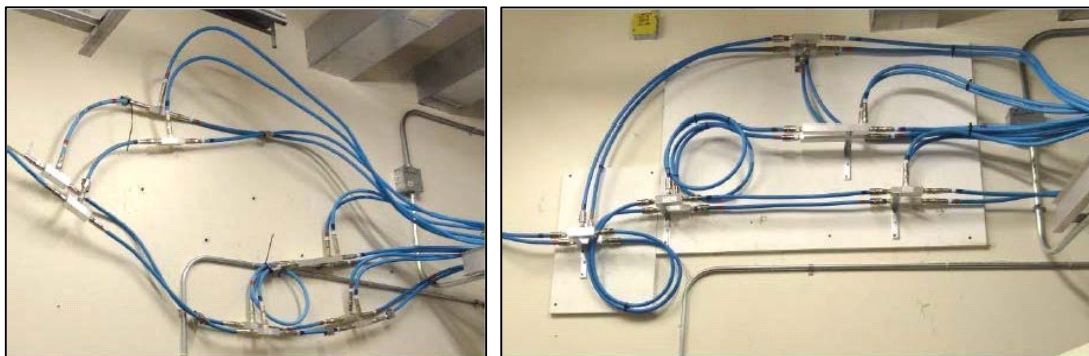

Figure 8 Initial and Improved Installation to Reduce Stress on RF Connections and Improve Testability

In this case, by securing the components to a wooden surface, adding cable stress relief and providing for appropriate tool access, the PIM performance became much more stable. Secure mounting provided a means to isolate mechanical stresses introduced during test and allowed for easy access of torque wrenches.

## 6 INSTALLATION GUIDELINES

All DAS components are specifically designed to transmit radio waves in a manner optimised to the radio frequency bands they are designed to support. All DAS components are exceptionally sensitive and may not operate properly if they are mishandled. For example, seemingly minor issues such as kinking or over-bending RF cable will disrupt its ability to properly transmit signal and will result in PIM difficulties or other defects – even after a damaged cable has been straightened. Similar performance problems will be encountered with optic fibre cables which are improperly handled.

The following processes will reduce the likelihood of installation defects which may lead to rejection of a DAS during the acceptance process by carriers.

Note that under no circumstances do the following instructions override Building Codes of Australia. Where there is any conflict with the building codes, installation contractor must follow Building Code of Australia.

**It is not acceptable for conduits containing DAS Cable to be ‘sunk’ into the concrete during the slab pour.**

### 6.1 CABLE HANDLING

Upon delivery of cable, each reel is to be inspected for damage. Reel numbers with cable lengths are to be logged at time of delivery.

Cable is to remain on the reels with lagging in place until delivered to the workplace for installation. Cable reels must always be transported or stored in the upright position.

Once delivered on site suitable reel stands, rated for the reel diameter and weight, must be used to unroll the cable for installation.

Cable should be unreeled carefully to avoid twisting. Care must be taken to ensure that the minimum-bending radius specified for repeated bends of each type of cable is not exceeded. Refer to Section 6.1.4 below for more details regarding bending radius.

If short cable pieces are cut off for installation from the reel, the cable ends must be protected again with caps to avoid water or dirt penetrating the cable.

Some fire rated cables are not UV resistant over a longer period of time and should, therefore, not be stored outdoors over a prolonged period of time, unprotected against UV radiation.

---

### 6.1.1 PASSIVE BACKBONE

All backbone feeder cables shall run to the equipment room and be terminated with a DIN 7-16 or 4.3-10 female connector that meets the approved equipment requirements of the Lead Carrier.

Wherever possible, cables are to be installed on the existing communication cable trays/ladders between the equipment room and the communications riser. It is the DAS contractor's responsibility to ensure sufficient space is available and where space is not available, additional cable trays/ladders must be supplied and installed.

If it is necessary to stack cables on top of each other, any cables that have connectors on the end must be installed in a manner that allows future access to the connectors.

The backbone cables must be secured to the cable tray at intervals not exceeding the manufacturer's maximum distance between supports.

The best method for attaching the cables to the trays is by use of nylon cable ties. If this is not possible any other approved fixing clamp may be substituted.

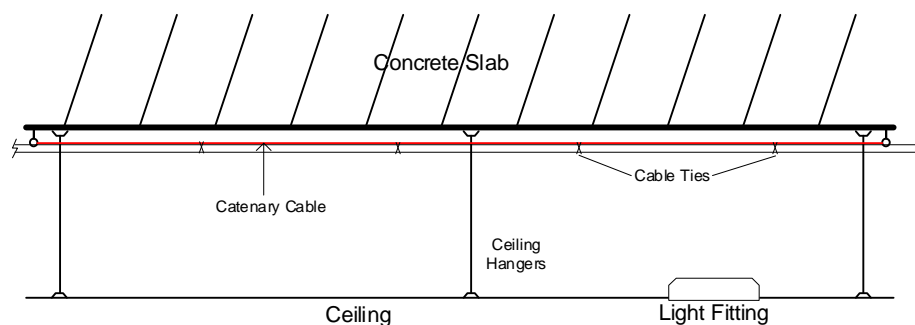

Figure 9 Typical Cable Installation on Tray

Figure 10 shows the layout of the backbone cable in a typical installation. The coupler shall be located in a position that is uncluttered and with a view to future maintenance. Both the coupler and cable should be secured to the riser wall or tray. Most couplers have holes to allow them to be screwed to the wall, but cable ties are also acceptable. Jumper cables may be omitted from one port if there is sufficient space to provide strain relief by putting a bend in a backbone cable.

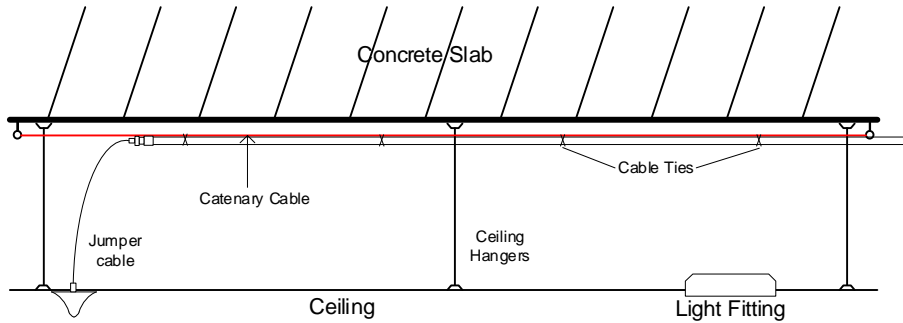

Figure 10 Distribution from backbone cable

All cabling in the riser shall be fixed neatly along the tray or to the wall with appropriate ties.

Fire-proof sealing shall be applied at all penetrations where a cable crosses boundary from one fire control region to another, such as from a riser into a floor area. Watertight glands shall also be installed where necessary.

---

#### 6.1.2 ACTIVE BACKBONE

The requirements described in Section 6.1.1 above are still applicable, however Optical Fibre or Ethernet cabling may be used to feed remote units in place of RF cables. All hybrid and active DAS cables must be approved by the Lead Carrier and must run to the common equipment room



---

### 6.1.3 BRANCH (FLOOR) CABLING

Cables run in the roof space cable must installed on catenary (best practice) or cable trays unless explicitly permission given otherwise. *Installers must ensure an approval explicitly authorising connection to ceiling grid hangers is obtained prior to connecting any cable to these hangers.*

Cables run in the roof space may be secured to the ceiling support hangers in accordance with Figure 11 if the distance does not exceed the maximum clamp spacing specified by the cable manufacturer.

The cable should be neatly fixed, taking the shortest possible path, allowing the maximum possible clearance above the ceiling tiles so as not to inhibit the lifting of ceiling tiles for maintenance purposes. Cable ties or clamps should be placed at intervals not exceeding the maximum clamp spacing specified by the manufacturer.

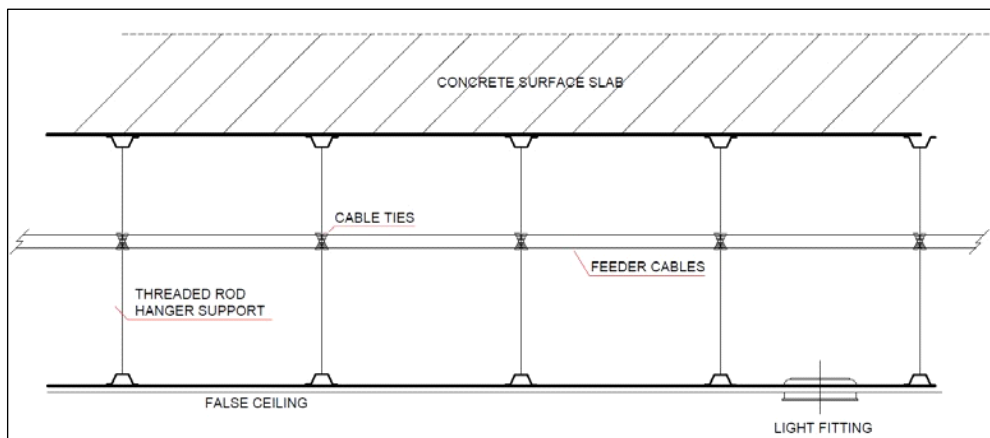

Figure 11 Branch (Floor) Cabling

---

### 6.1.4 CABLE BENDING RADIUS

When installing any cables, they must not be bent more than the manufacturer specified minimum bending radius. There are two different specifications for most cables:

- i) Single bend; or
- ii) Multiple bends.

Generally the single bend specification refers to the instance where a cable is bent in one direction only – for example, a right angle or in a loop. The multiple bend specification covers the instance where a cable is bent in one direction then back again as in an S bend. In cases where

only a multiple bend radius is specified by the manufacturer, this must also apply to a single bend.

If cables are bent beyond the manufacturer's specification at any time, it is highly likely the outer conductor will be distorted. Although this may not be visible, it often severely impacts performance of the cable. Only testing will reveal this. The only remedy is replacement of the affected cable.

---

#### 6.1.5 CABLE TENSILE STRENGTH

The maximum weight that can be applied longitudinally to any point of the cable is classified as its tensile strength. The tensile strength of RF and Fibre Optic cables is provided by manufacturers.

When hauling cables either horizontally across a cable tray or vertically up a riser, care must be taken not to exceed the tensile strength of the cable. If too long a length of cable is hauled, exceeding its tensile strength, the cable will be stretched damaging the cable and degrading its performance.

If a cable is hauled up a riser and only supported from its end point, the total weight of the cable must not exceed the tensile strength of that cable.

---

#### 6.1.6 RF CONNECTORS

Good connector termination is paramount to good PIM performance. Great care and use of the correct cable preparation tools is essential. No cable should be prepared with the use of hand tools. Always use the manufacturer's recommended tools. Connector fitting to twisted pair cables is important and the appropriate shielded connectors are required. Poor Return Loss and frequency response of twisted pair can result in no communication between hub and remote small cell.

When cutting cable with a hollow center conductor, ensure no fillings remain within the center conductor otherwise poor PIM performance may develop over time – normally as the RF loads being carried through the DAS increase.

All manufacturers have instructions on connector termination which must be sourced for each different type of connector used and must be followed.

### 6.1.7 FEEDER CABLE MOUNTING (NON-RADIATING CABLE)

The cable should be neatly fixed, taking the shortest possible path, to the ceiling grid hangers by cable ties, allowing the maximum possible clearance above the ceiling tiles so as not to inhibit the lifting of ceiling tiles for maintenance purposes. Cable ties should be placed at intervals of not more than 2 metres. Note the requirements of Section 6.1.3 with respect to the use of ceiling hangers.

Cables under concrete slab needs to be attached at intervals of not more than 2 metres.

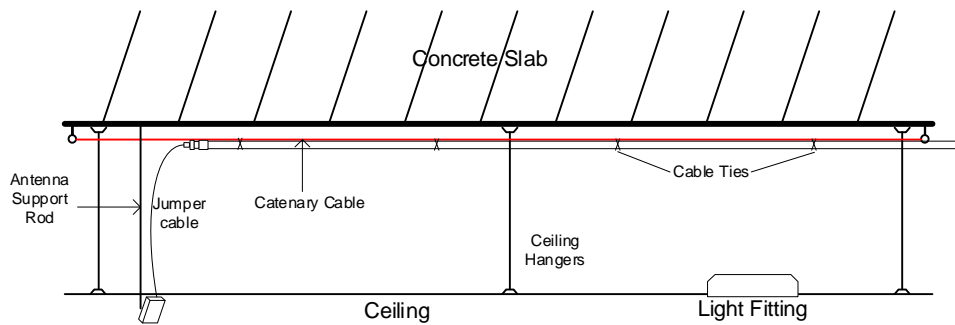

Figure 12 Floor Cable Mounting

### 6.1.8 RADIATING CABLE MOUNTING

In all situations involving deployment of radiating cable, the manufacturer's installation recommendations must be followed.

Radiating cables are not recommended for general use in applications where placement may lead to difficulties associated with PIM throughout the life of the DAS. The use of radiating cable must be specifically approved by the lead carrier in all proposed installations.

## 6.2 ANTENNA INSTALLATION

Antennas should always be installed far away, as practical, from metallic items that may affect their radiation pattern or cause PIM issues. They should also be mounted below any obstructions that will affect their radiation pattern.

When flexible tails are supplied as part of the antenna, patch leads should not be used to connect the antenna to the feeder. However, it is an acceptable installation technique to use a male connector on the end of a feeder where there is insufficient length in the manufacturer supplied antenna-tail for direct connection. Whilst it is not preferable an option to use tails is possible depending on construction constraints.

## 6.2.1 MOUNTING OF OMNIDIRECTIONAL ANTENNAS

The space around the antenna (including the ceiling space) should be as clear of metal objects as possible to minimise the generation of intermodulation products and prevent distortion of the radiation pattern.

Ideally, there should be no metal objects within 600mm of the antenna. In practice, locate antennas centrally in or on a ceiling tile to maximise the spacing from the supporting grid and place as far as from ductwork, cable trays, emergency lighting, door openers, etc.

Omnidirectional antennas must be installed on the underside of the ceiling. Alternate antenna locations which do not meet this requirement (e.g. for aesthetic reasons) must be specifically approved and installed subject to the conditions indicated by the Lead Carrier who will be responsible for the ongoing operation and performance of the DAS.

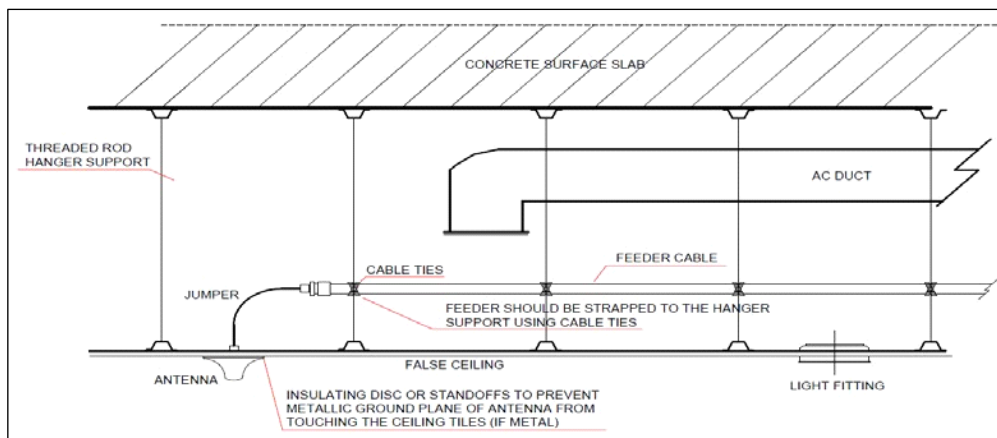

Figure 13 Omnidirectional antenna installation below false ceiling

Ensure that the metal ground plane of the antenna is insulated from the metal ceiling tiles, by using an insulating disc, insulated standoffs or in some cases the radome of the antenna may provide an effective stand-off if it wraps sufficiently over the edge of the ground plane.

Antennas which have a non-metallic securing nut are preferred in this situation. When screws are required to secure the antenna to the ceiling, use non-metallic screws, nuts and washers (nylon or similar).

When there are no false ceilings, the antenna must be supported on a bracket in such a way that the antenna is below the height of any obstructions. Where there are no obstructions, such as in a car park, the antenna can be fixed against the concrete slab.

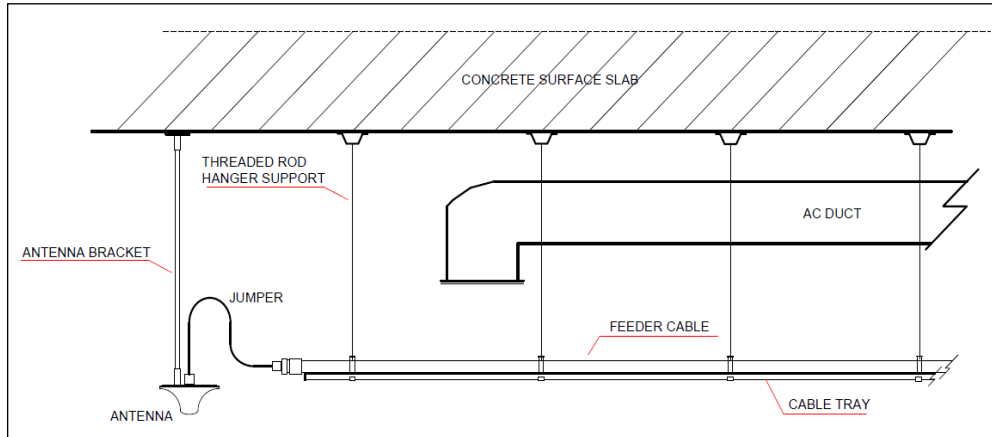

Figure 14 Omnidirectional antenna mounted where no false ceiling exists

### 6.2.2 MOUNTING OF PANEL ANTENNAS

The panel antenna is a directional antenna. It needs to be mounted away from metal surfaces to minimise the generation of intermodulation products and prevent distortion of the radiation pattern. There cannot be metal objects within 1.2m of the coverage arc in front of the antenna.

Specify installation of panel antennas on a wall or the underside of the ceiling. Alternate antenna locations which do not meet this requirement (e.g. for aesthetic reasons) must be specifically approved and installed subject to the conditions indicated by the Lead Carrier who will be responsible for the ongoing operation and performance of the DAS.

The antenna must point in the same direction as specified in the design. If this cannot be achieved by flush mounting against a wall, then a bracket allowing rotation will be required.

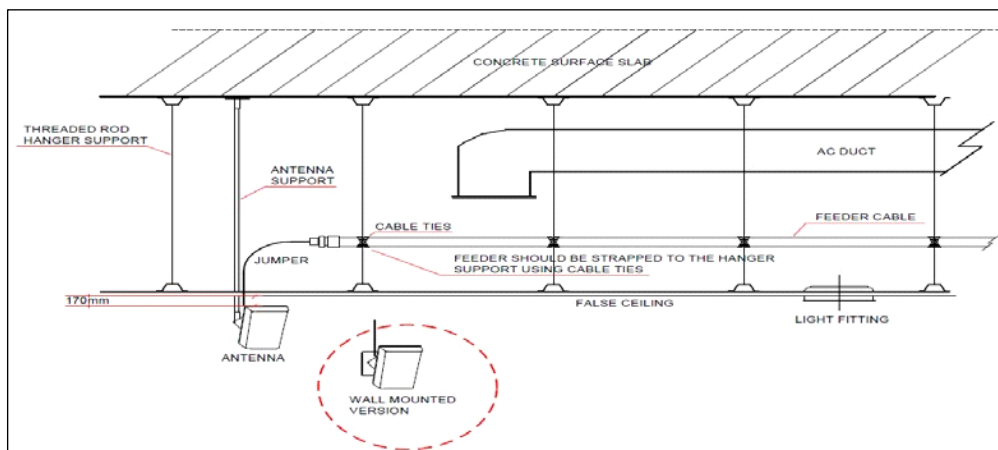

Figure 15 Mounting of panel antennas

### 6.3 SPLITTER MOUNTING

The components must be located in a position that is uncluttered and which provides good access for future maintenance. Both the component and cable should be secured to the riser wall or tray.

Some splitters or couplers have holes to allow them to be screwed to the wall, these may be used if adequate clearance is available to remove cables when installed. Where adequate spacing is not available, tailor made support brackets and cable ties must be used to secure the component.

Adaptors must never be used to connect cables or components together.

Under no circumstance is a component to be installed so it is only supported by the cables attached to it.

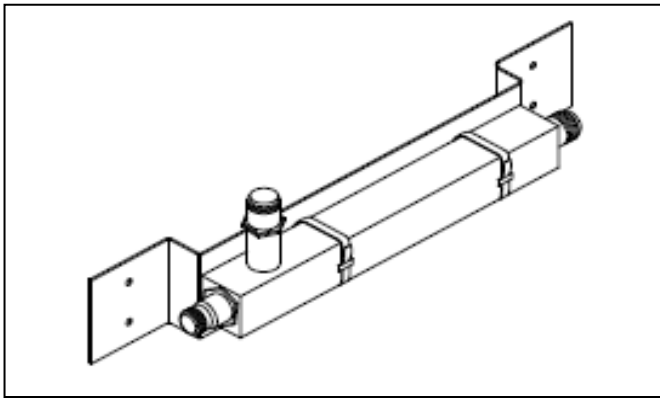

Figure 16 Example of splitter / coupler mounting bracket

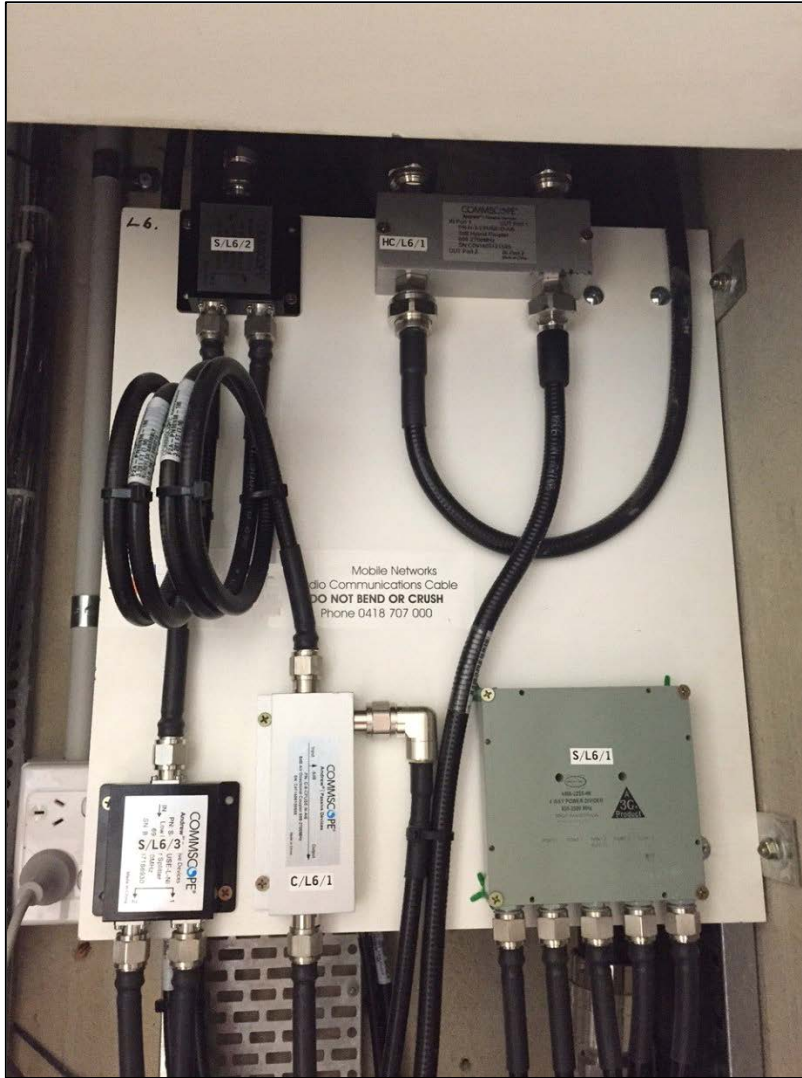

Figure 17 Typical Installation

## 6.4 JUMPER CABLES

The use of jumper cables should be considered and factored at the design stage to avoid:

- a. physical installation constraints – for example, it is not possible to install what has been designed in a manner that will physically fit, or be technician-serviceable; or
- b. insertion loss impacts – for example, the only viable physical installation at site results in an under-powered system due to insertion losses resulting from using more jumper cables than anticipated.

All connectors must be torqued in accordance with the manufacturer's standards.

When connecting cables to couplers or splitters, no more than one (1) rigid cable should be connected directly to the component. Jumper cables must be used to connect all additional cables to the splitter or coupler to prevent excessive stress being placed on the connectors. The final selection of which rigid cable is directly connected to a port of the component is not critical and may be selected during construction in order to achieve the tidiest installation.

Where it has been determined that it is better to use jumper cables for all ports of a component, it is important to confirm the additional insertion losses remain consistent with the power levels from the original design, and arrange recalculation – particularly towards the far end of the distributed antenna system. Insertion loss problems may become more significant when the use of jumper cables is repeated many times in the backbone.

As noted in Section 6.2 above, a jumper is not required when an antenna has a flexible tail.

Normal practice is to put a loop in the jumper cable to further minimize any stress being placed on the connectors. Use of this installation technique also makes it much easier to disconnect components, which will be necessary in the later testing phases. Figure 17 shows a well organised installation utilising jumper cables.

**IMPORTANT:** If jumper cables have not been specified in the design but they are used during installation, the as-built configuration must be recalculated and reassessed by the designer as it may have an adverse impact on the original design due to extra insertion losses.

## 6.5 OPTICAL FIBRE INSTALLATION GUIDELINES

Optical cable is sensitive and will not perform correctly if it has been incorrectly installed or the cable integrity has been compromised (over-bent etc.) during the installation process.

Where the DAS installer has provided optic fibre as part of the DAS, it must be installed and tested to meet the performance specifications indicated in Section 3.18.9.1 and 7.7.

### 6.5.1 OPTICAL FIBRE CABLING IN EQUIPMENT ROOMS

All cables must be terminated into a patch panel. Patch panels with inbuilt splicing trays must be used.



On smaller jobs a single RU unit that typically has 12 connectors can be used. For larger fibre count cables, larger tray units which have multiple rows of connectors should be used. These allow pigtailed cables to be spliced onto the fibres and then terminated into the patch panel. These should be mounted into the same cabinet as the Active equipment. Cable management systems must be utilised to keep all cabling neat.

The connector type must be SC or SC-APC as recommended by the equipment vendor.



Figure 18 Optic Fibre Rack-mounted Splice Tray and Patch Panel

---

### 6.5.2 REMOTE UNIT CABLING

Cables to the remote units must be terminated into a small patch panel. These termination boxes are to be fixed to either the ceiling or another permanent structure that provides suitable support and protection. Pigtailed cables are to be spliced onto the end of the fibre and terminated in the box.

Jumper cables shall be used between the termination box and the remote unit. The patch ports are to be labelled as per the corresponding patch panel port in the main equipment room.

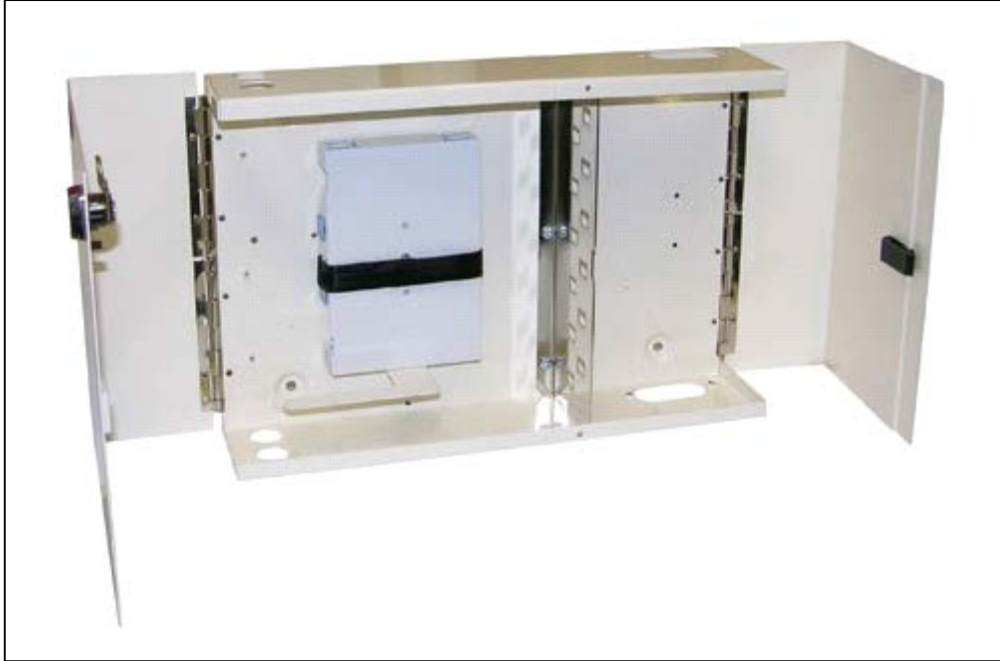

Figure 19 Optic Fibre Splice Tray and Patch Panel

An acceptable alternative to using patch cables is to splice flexible cables directly onto the end of the fibre. Where this solution has been applied, the splices must be done in a splice box as per the illustration in Figure 20.

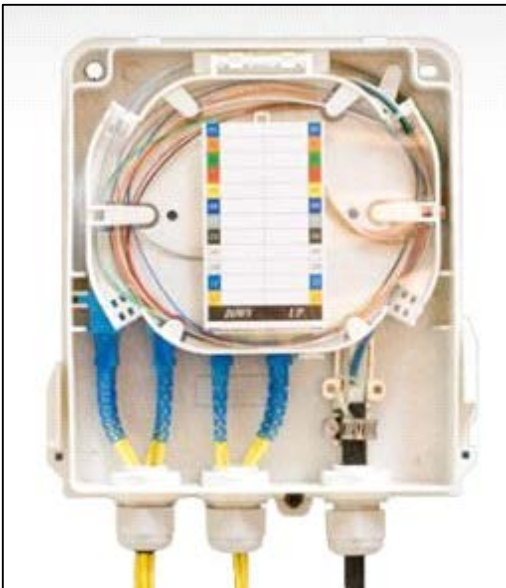

Figure 20 Optic Fibre Splice Box

## 6.6 OPTICAL FIBRE CABLE INSTALLATION

All cabling must be supported on cable trays / ladders, catenary cables or in conduits. The cable should be neatly fixed, taking the shortest possible path, allowing the maximum possible clearance so cables do not get snagged or damaged during any building maintenance activities which may occur in vicinity of the cable (e.g. secure cables so they do not inhibit lifting of ceiling tiles etc.)

Velcro straps are the preferred attaching method to trays etc. When using cable ties to secure cables, they should be left a little loose around the cables to avoid possible damage to the fibre.

## 6.7 GPS ANTENNAS

Where GPS Antennas and feeders are required and they are expected to be installed by the DAS installer, the Carriers will provide them.

Cabling between the GPS antenna and the equipment room/s must be installed as per the guidelines in Section 6.1. Where different types of cables are provided, the cable manufacturer instructions must be followed. There must be particular attention given to the suitability of the maximum cable length and cable type for the amount of power.

GPS antennas will also require the GPS feeder to be earthed (lightning protection earth).

Cables must be terminated into the GPS antenna and the tails left coiled with sufficient excess cable available to allow for termination into carrier base stations. (Note: It will always be better to leave too much cable for the carrier commissioning crew to shorten when terminating into the base station, rather than insufficient cable.)

## 7 TEST RESULTS

### 7.1 INSTALLATION / TEST REPORT

The final DAS commissioning report submitted pursuant to Section 4.5 above must provide all of the following:

Information Type	Reference Section
Any Target Coverage Area exclusion zones with reasoning shown on floor plans	<a href="#">3.3</a>
Test Equipment Used	<a href="#">7.2</a>
As-built walk test results	<a href="#">7.6</a>
All sweep results (Return Loss – RL and Distance to Fault – DTF)	<a href="#">7.3</a>
Insertion Loss	<a href="#">7.4</a>

Information Type	Reference Section	
PIM results tabulated and referenced to relevant section of DAS	<a href="#">7.5</a>	
Floor Plans showing all hardware locations	<a href="#">4.5</a>	iBWave files will have floor plans / schematics / composite power /BOM etc. and can be submitted in lieu of individual items.
Schematic diagram	<a href="#">4.5 ref</a>	
Composite power table	iBWave4.5 ref	
Bill of Material (BOM) used	iBWave4.5 ref	
Optic Fibre Testing/Commissioning	<a href="#">7.7</a>	
Equipment room layout diagram	<a href="#">4.3</a>	
Sectorisation plan	<a href="#">4.3</a>	
Any configuration settings for Active systems	<a href="#">4.3</a>	
Any site specific details that may be required to maintain the site e.g. circuit breaker number and location	<a href="#">4.3</a>	
Site Access details	<a href="#">4.3</a>	
Other DAS information reasonably required for operation and maintenance of the DAS. (May be requested by the Lead Carrier)	<a href="#">4.5</a>	

Table 13 Installation/Test Report

## 7.2 TEST EQUIPMENT USED

List of all test equipment including:

- Type / Manufacturer / Model number
- Serial number
- Calibration date
- Purpose of test and configuration used for test

## 7.3 RF SWEEPS

All RF cables used in the DAS must be swept / have a return loss measurement performed across all frequency bands indicated in Section 2.5 above. This comprises 703 MHz to 960 MHz and 1710 to 2690 MHz bands.

If any cable is found to not meet specification as listed by the cable manufacturer, the problem must be found and rectified.

All RF sweeps are to be recorded in a similar format as per the diagram below with the cable number and also supplied in electronic format to the Lead Carrier for validation and acceptance. The measurements must also be recorded in a spreadsheet summarising all measurements made and show pass/fail status with cross-referencing to the relevant cable number provided in the result.

The date (DD/MM/YYYY) of all measurements must be included in the supplied spreadsheet.

All cables must have a distance-to-fault test performed to validate the installed length of the cable. If the distance-to-fault length is more than 10% different to the design for that cable, it must be highlighted back to the designer and recalculated in the as-built documentation to demonstrate it has not adversely impacted the design.

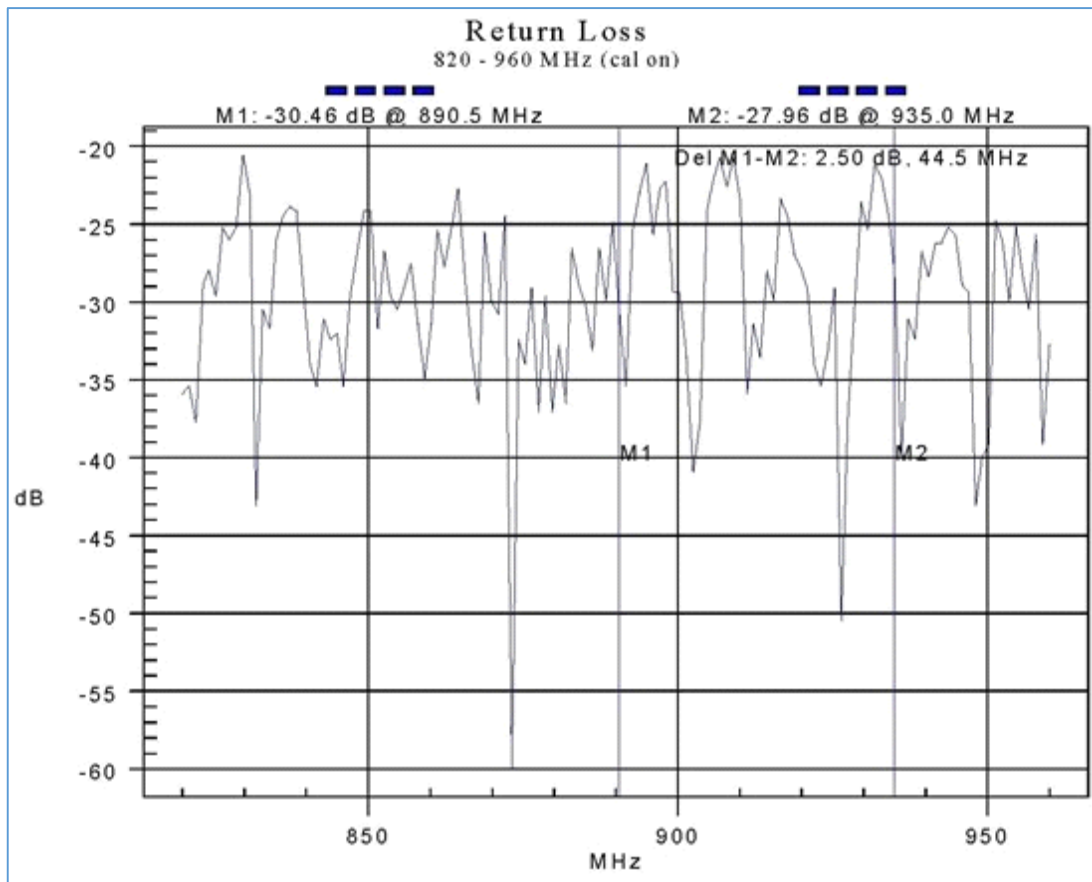

Figure 21 Example of a Return Loss Sweep

## 7.4 INSERTION LOSS

The backbone distribution system must be checked and verified against design values for its insertion loss in both a low band and a high band. The tests shall use a 3GPP low band and a high band selected from:

- Low Band = Band 5, 8 or 28
- High Band = Band 1, 3 or 7

A signal must be fed in at the base station end and the level out must be measured at the final splitting or coupling point to each floor. Where a splitter feeds more than one floor or there is more than one output from the same splitter to a floor, only one output needs to be tested. The difference between the input level and the output level must be recorded as the insertion loss.

All measurements for insertion loss must be tabulated as per the example below and supplied in electronic format to the Lead Carrier for validation and acceptance:

Test Point	Frequency (3GPP Band)	Input Point	Input Power	Output Power	Measured Insertion Loss (a)	Original Design Insertion Loss (b)	Delta (b) – (a)
Splitter S/3/1	860 MHz	BC/B2/1	+20 dBm	-3 dBm	23.0 dB	22.0 dB	-1.0
Splitter S/3/1	2690 MHz	BC/B2/1	+20 dBm	-7 dBm	27.0 dB	25.0 dB	-2.0
Splitter S/11/1	860 MHz	BC/B2/1	+20 dBm	-7 dBm	27.5 dB	28.0 dB	0.5
Splitter S/11/1	2690 MHz	BC/B2/1	+20 dBm	-7 dBm	34.5 dB	27.9 dB	-6.6

Table 14 Example of Insertion Loss Report

Note: insertion loss tests help quickly determine if any directional couplers have been installed incorrectly or there is a fault in the RF path.

## 7.5 PASSIVE INTERMODULATION TESTING

Passive intermodulation testing shall be carried out in accordance with the document published and maintained by The International Wireless Industry Consortium (IWPC) titled “*TTER: Passive Intermodulation Testing Best Practices*” using 2 x 43 dBm carriers to determine the PIM performance of the installed DAS.

Link to document: <http://www.iwpc.org/WhitePaper.aspx?WhitePaperID=18>

Link to IWPC: [www.iwpc.org/](http://www.iwpc.org/)

Testing must be done in at least two frequency bands comprising both a low band test (700/850/900 MHz) and a high band test (1800/2100/2600 MHz). Test results shall be provided showing reflected third-order PIM measurements at the following points:

- Each input of the multi-network combiner
- Each segment connected to multi-network combiner outputs (measured at the point which connects to the multi-network combiner, i.e. including cable tails).

For Active systems, PIM testing must also include the point of interconnect after the remote unit. Where an Active DAS has a composite output power  $\leq 5$  watts, the above PIM testing shall be undertaken with 2 x 33 dBm carriers rather than 2 x 43 dBm carriers.

A table of the results, (in either PDF or excel format) of the PIM test results must be submitted, summarising all measurements made and all pass/fail statuses.

Photographs/screenshots showing correct date (DD/MM/YYYY) and time (HH:MM:SS) of PIM measurements must be supplied. At the time testing is undertaken, the PIM test equipment must show the correct time of day for the time zone in which the DAS operates.

## 7.6 WALK TESTS

Post implementation walk surveys (aka snail plots) with survey readings must be plotted against final versions of building floor plans.

Separate plots are required for each frequency band (where installed) and technology which will be in operation from handover of the DAS. If no carriers are connected, test transmitters should be used at a low band and high frequency:

- Signal levels (both downlink (RSRP/RSCP) measurements and uplink Tx power)
- Quality
- Serving cell
- Rank indicator (applicable only for MIMO)
- Dominance over macro
- Handover zones
- Lift car vertical plots in elevation view
- Demonstrating every installed antenna is operational
- Active call sessions

---

### 7.6.1 WALK TEST ROUTE

The walk test route must cover all trafficable areas of the building and meet or exceed the performance requirements for >95% of locations specified throughout this document.

The walk test route must specifically demonstrate DAS performance at the external perimeter of each floor (to validate the DAS provides dominance over the macro apart from any agreed exclusion zones) along with performance within the Target Coverage Areas as defined in Section 3.3.



Frequency Band	Telstra	Optus	Vodafone	TPG	Other
700MHz					
850MHz					
900MHz					
1800MHz					
2100MHz					
2300MHz					
2600MHz					

Table 15 Walk tests to be conducted for all technologies and frequency bands which will operate from DAS handover

### 7.6.2 WALK TEST MEASUREMENTS

For LTE technology, the signal strength measurement must be RSRP in dBm for each PCI and the quality measurement must be CINR or SINR in dB for each PCI.

For WCDMA technology, the signal strength measurement must be RSCP in dBm for each PSC and the quality measurement must be  $E_c/I_o$  in dB for each PSC.

### 7.6.3 WALK TEST RESULTS

The results for walk tests are to be recorded using graduated- colour coded snail trail in a manner similar to Figure 22.

The log files for these tests must be supplied to the Lead Carrier as directed. This will typically be on a CD/DVD or uploaded to a web-based file server which is accessible by the Lead Carrier.

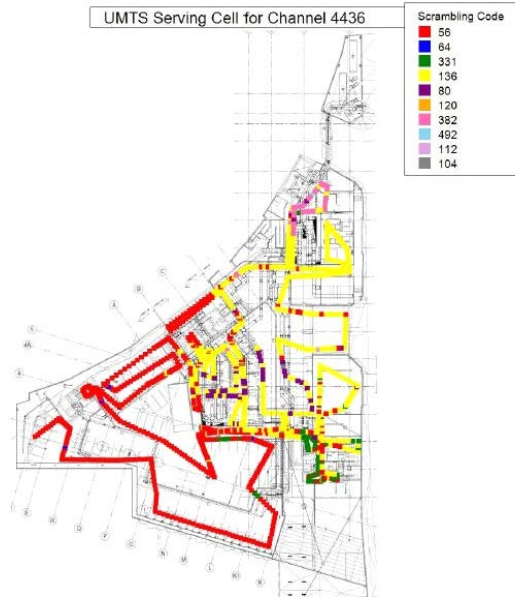

Figure 22 Example of colour-coded snail trail result

#### 7.6.4 LIFT CAR VERTICAL PLOTS

The carriers will be interested to see a demonstration of RF penetration into each lift car installed at the premises and the behaviour at handoff between sectors within a lift – e.g. travelling through different sectors, or in the case of door closures leading to a sector handoff depending on the design architecture. Lifts which service high rises and by-pass lower levels (i.e. lifts which do not gain signal through lift doors in the lower levels of a building) will be a particular focus.

The two primary test scenarios which will demonstrate satisfactory in-lift performance are:

- 1) High speed travel through the entire lift run non-stop from end to end; and
- 2) Stop at each level, open doors and close doors.

The recording method to plot results will depend on the type of test being conducted – for example, a high speed lift-travel run would likely use an established frequency of (say) 5 samples per second to plot performance as a user travels through the lift shaft from end to end (lowest level to highest level serviced by that particular lift). Whereas lift door-stop tests may use manual sampling at each floor.

## 7.7 OPTIC FIBRE TESTING & COMMISSIONING

### 7.7.1 OPTICAL TIME DOMAIN REFLECTOMETER (OTDR)

Either “Mini” or “Full Featured” OTDR instruments, immune to polarisation noise and conforming to the Telcordia GR-196-CORE “Generic Requirements for Optical Time Domain Reflectometer (OTDR) – Type Equipment” are to be used for all OTDR measurements.

The OTDR must be capable of storing the traces on an electronic medium (e.g. USB stick) for transportation/submission; allow retrieval and reading of traces. All traces are to be stored and submitted – preferably in a format compatible with Telcordia standard SR4731- Issue 2 (SOR).

OTDR testing shall be performed on all fibres in both directions (two-way) at 1310 and 1550 nm.

Visual inspection of optic connector end faces to meet the IEC standard (IEC 61300-3-35).

Please reference AS/NZS ISO/IEC 14763.3:2012) and 2. TIA-568 C.3, as these will allow auto-population of parameters.

### 7.7.2 SECTION LINK LENGTH

The Section Link Length (L) or the optical OTDR Link Length is measured from the 1550nm OTDR trace. This is required for the theoretical calculation of OTDR Link loss (LL) and for calculation of Insertion Loss criteria.

### 7.7.3 OTDR LINK LOSS

OTDR Link Loss measurements must be completed on all fibres to confirm the integrity of the cable link without including the performance of the end connector/pigtails. These results can be achieved contingent on the use of core based splicing machines, and quality pigtails.

Two-way averaged OTDR Link Loss (LL) is measured at 1550nm and 1625nm from the bi-directional OTDR traces, as  $LL_{\lambda=1550nm}$  and  $LL_{\lambda=1625nm}$  respectively. The measured OTDR Link Loss shall conform to the following criteria:

- $LL_{\lambda=1310nm} \leq 0.35L + 0.1N + 0.3$ ;
- $LL_{\lambda=1550nm} \leq 0.21L + 0.1N + 0.3$ ; and
- $LL_{\lambda=1625nm} \leq 0.25L + 0.1N + 0.3$

L = the optical OTDR link Length in km (measured at 1550nm)

N = Number of splices excluding pigtail terminations.

Compliance with these parameters must be demonstrated at the time of DAS handover. The DAS Contractor will be required to resolve any anomalies and achieve this criteria.

## 8 CARRIER EQUIPMENT & ACCOMMODATION REQUIREMENTS

This Section outlines the typical accommodation and provisioning requirement for carriers which should be provided for a DAS. The specific nature of carrier requirements will vary depending on the capacity requirements for the site and the type of DAS solution which will be used. The Lead Carrier will advise specific requirements.

### 8.1 CARRIER ROOM SPECIFICATIONS

The equipment room contains base station equipment that will be installed and connected to the Distributed Antenna System (DAS). The floor space required to cater for 4 carriers is a minimum of 32m<sup>2</sup> (based on a 6m x 8m room size).

### 8.2 CARRIER EQUIPMENT RACK SPACE REQUIREMENTS

The minimum space requirement is 4 x racks per carrier = 16 racks total. The Lead Carrier must be consulted to determine whether more space may be required.

Equipment Rack Dimensions:–

- External Height – 2500mm
- External Width – 600mm
- External Depth (Including Door) – 1200mm

### 8.3 POWER

#### 8.3.1 SURGE AND LIGHTNING PROTECTION

Following requirements are to be provided at the incomer of the DAS Room distribution board to reduce the impact of lightning strikes. Distribution board requirements:

- One DB is required and shall be wall-mounted within the room.

- 1 x 36-pole MCB chassis.
- The DB will have a 160A isolator, surge protection at the incomer only,
- One energy meter
- The DB will be provided with a 100A essential (generator-backed) supply, where possible.
- The circuit breakers within the DB for supply to the carrier's equipment are to be supplied and installed by the carriers.

RF cables must be connected to earth immediately after entry into the carrier room if they are exposed to any external environment.

---

### 8.3.2 AUXILIARY POWER AND REDUNDANCY

Uninterrupted Power Supply (UPS) is typically not required as each carrier will provide their own batteries within their own racks.

In DAS deployments, Carriers usually deploy their equipment with up to 3 hours of battery backup power in case of power outages. This configuration will enable normal function of all components of Passive DAS which may be directly fed from the carrier radio equipment for up to 3 hours.

Any remote Active DAS equipment which is not connected to auxiliary power will not be available during power outages unless the requirement is factored into DAS design.

In cases where more robust communications service levels may be specified or required (such as tunnels, hospitals, or other critical infrastructure environments), the Lead Carriers must be engaged to co-ordinate auxiliary power solutions. These solutions may involve shared use of building generators or in some cases more battery strings (which will have floor loading implications).

As indicated above, special consideration for provision of backup power to remote Active DAS equipment should also be addressed where there may be an expectation of continued mobile communication during power interruptions.

---

### 8.3.3 POWER SUPPLY TO AIR CONDITIONING

Equipment room air-conditioning must be kept on a separate power supply.

## 8.4 AIR CONDITIONING

The standard requirement is for minimum of 12KW split air conditioning system on a 1+1 (hot standby) configuration. This requirement can change based on what or how many technologies are deployed by the carriers. The Lead Carrier will provide confirmation upon request. The average heat load per operator will also depend on the DAS configuration, as an active system will be hotter in a single room, whereas remote radio units will introduce heat in other locations.

Carrier equipment generates heat. In certain environments and climatic conditions, the humidity and dew point differentials will lead to condensation. It is important to eliminate condensation / water drip risk to equipment from any vents, pipes or ducting which may be located directly above carrier equipment or DAS equipment. Cassette-style air conditioner units are particularly prone to drip and must not be installed directly above carrier equipment or DAS equipment.

As stipulated in Section 8.3.3 above, air conditioning is to be provisioned on a separate power circuit.

## 8.5 FIRE PROTECTION

The carrier equipment room should be 2-hour fire rated (inside and out) due to the probability that batteries installed in the room by the carriers will have a voltage exceeding 24V and capacity exceeding 10Ah (BCA Clause C2.12).

Monitored fire alarming is preferable to sprinklers inside the equipment room; this is not compulsory but preferred by the carriers.

## 8.6 CABLE MANAGEMENT

600mm basket leading up to the communications room with a 600mm wide by 100mm high penetration into the communications room for COAX and Fibre access. All steel works should galvanized and with proper edging protection/caps

## 8.7 REMOTE MULTI-NETWORK COMBINER (MNC) LOCATIONS

In all cases the DAS supplier must provide an MNC which supports the frequency bands listed in Section 2.5 and the performance requirements detailed throughout Section 3.0 as part of the DAS installation.

It is the responsibility of the carriers to each connect their base station equipment to the MNC.

It is strongly preferred and typically more practical for all parties to have a single common location for all the DAS equipment, including the MNC and carrier base station equipment.

Difficulties may arise and additional connection charges may apply for carrier connections to the DAS if the MNC is not located within the carrier equipment room.

In situations where carriers are attaching to a DAS through an MNC that is not located within the carrier equipment room, the methods used by carriers to connect to the DAS will vary depending on the circumstances. The DAS supplier must ensure the following provisions are made:

Connection from a carrier remote active base station unit requires:

- 240V power supply\*
- 1 Rack space per operator (per dimensions in Section 8.2 above) – within 50m (cable length) of the MNC and a cable path for up to 7/8 feeder cable.

Direct RF feed from carrier base stations require:

- Cable path from carrier base station equipment to the MNC allowing space for at least 4x 7/8 feeder cables.
- In cases where the MNC cannot be located within 50m of the base station equipment, consideration should be given to deploying an Active DAS solution. This should be done in consultation with the Lead Carrier.

\* Carrier remote active base stations do not have space for auxiliary batteries, so this arrangement may not be able to operate during power outages. Refer to Section 8.3.

## 8.8 TRANSMISSION

Building “lead-in” optical fibre conduit access must be provided from the carrier equipment to the nearest fibre access point (FAP) outside the premises in order for mobile carriers to connect their radio base station equipment from the equipment room to the carrier’s network.

The conduits should be sufficient to support independent fibre for each carrier.

## 8.9 LIGHTING

Minimum 500 Lux evenly throughout the equipment room. Dual fluorescent tube light fittings are usually sufficient.

## 8.10 ROOM FINISH

Fully enclosed room, walls floor to ceiling.

Vinyl Floors are preferred; alternatively the floor is to be painted with a non-slip anti-static paint up to a wall height of 300mm.

#### 8.10.1 ROOM FINISH SUMMARY TABLE

Item	specification	Comment
Floor Finish	Vinyl or non-slip anti-static paint	
Wall Finish	Painted	
Ceiling	Not specified by carrier	
Joinery	Not Required by Carriers	
Data Outlets	None required by carriers	
Cable Management	Comms tray/penetration into carrier room	<i>Refer 6.0, 8.6, 8.8</i>
GPO's	Distribution Board Only	<i>Refer 8.3</i>
Fire Protection	2-hour fire rated	<i>Refer 8.5</i>
Security Door	Key is preferred	<i>Refer 8.11</i>
Racks	Carrier supplied	<i>Refer 8.2</i>
UPS	Typically carrier supplied	<i>Refer 8.3</i>
Surge protection	YES	<i>Refer 8.3</i>
<i>Air Conditioning</i>	<i>12KW 1+1 Hot standby configuration</i>	<i>Refer 8.4</i>

Table 16 Room Finish Summary Table

## 8.11 DAS SECURITY

The Lead Carrier will require the carrier room and any remote equipment locations to be secure and allow them access for any ongoing maintenance or system issues. Where possible, access to the equipment locations must be restricted to authorised persons and be controlled with a key or card reader.

### 8.11.1 SECURITY OF POWER AND TRANSMISSION TO REMOTE EQUIPMENT LOCATIONS

Active DAS equipment is usually located remotely from the carrier equipment room. To preserve operational integrity of the DAS and mitigate risk due to deliberate tampering or inadvertent disconnection (e.g. cleaners unplugging equipment to use a GPO, fibres being cutover to another user etc.) it is important the remote equipment is adequately protected in the context of its installed environment.

The use of locked enclosures, captive GPO's or hard-wiring for remote equipment with a key-operated power isolation switches held by the Lead Carrier may be appropriate solutions. The



most appropriate solution will depend on the environment and the particular circumstance. Consult with the Lead Carrier for further direction on this subject.

Refer to Section 3.18.9 for discussion on the cables connecting remote Active equipment to the DAS.

## 9 DEFINITIONS

### **Passive DAS**

A passive DAS is typically divided into two main components:

- A. The backbone feed system which forms the distribution to each floor or area; and
- B. The floor/area cabling.

The backbone is generally composed of cables, splitters and couplers. The preferred network topology is for groups of floors/areas (up to 4) to be fed from a multi-way splitter, which in turn is fed from a trunk cable from the carrier base station (or from a higher level splitter where there are more than 4 floors/areas).

The floor cabling can be a combination of any of radiating cable, coaxial cable, antennas and terminations.

### **Active DAS**

An Active DAS typically has an interface unit which converts an RF signal from the base station to either analog (IF), digital or optical signals. This interface unit is typically co-located with the carrier base station equipment. From the interface point, typically optical fibre distribution or Ethernet cables are used to feed remote active heads which convert the optical signals back to RF signals and are then connected to individual antennas or to a small passive distribution system (Hybrid DAS).

Active systems may be multi-band, and/or support multiple technologies. For example, a tri-band / multi-technology system could have 3G850, LTE1800 and 3G2100 amplifiers in a common remote head.

### **Hybrid DAS**

This configuration generally takes the form of an Active DAS, which then feeds into smaller passive DAS tributaries.

Another configuration might be a multi-sector solution where a common base station feeds an Active DAS in one section of the building, but has another indoor coverage area served by a Passive DAS.

### **Lead Carrier**

A member of the Mobile Carriers Forum who is the owner and operator of a public mobile telecommunications network in Australia. The current Carriers providing such services are Optus, Telstra, TPG and Vodafone.

### **Exclusion Zones**

Area that are to be excluded from the in-building coverage requirement. Areas such as storage areas, and very low traffic areas are typically in this category .

### **Passive Intermodulation (PIM)**

Refer to Section 5.1

### **Sharing Carrier**

A network operator connecting to a DAS and relying on the Lead Carrier to operate and maintain the DAS.

### **Fixed Line (PTSN/NBN)**

These services are the most reliable communications solution, however in today's era there is a strong preference for people to be "unwired." The inconvenience of multiple devices, multiple phone numbers and the inability for automatic intelligent call diversion or simple and seamless transitions of active phone calls to/from a mobile handset to/from a fixed line handset have typically lured consumers and business to the convenience of just having a mobile phone and favouring wireless solutions.

### **VoWiFi (Voice over WiFi)**

VoWiFi (Voice over Wi-Fi) requires a reliable broadband connection to the end-user and then leverages privately supplied Wi-Fi coverage provided by the end-user. The technology for seamless carriage of VoWiFi through mobile telephone accounts is still being developed and each carrier will have different security protocols to enable VoWiFi carriage through their respective

network cores. Although VoWiFi may provide the ability to make and receive phone calls through a mobile handset (according to pre-set parameters while within a particular Wi-Fi coverage area), these solutions are unlikely to maintain a call connection when moving between different Wi-Fi coverage areas. Effectively, this means the quality of service using VoWiFi could be limited and may not be a satisfactory solution given calls might be dropped when moving through different areas.

### **Small Cells**

Small Cells are carrier-specific and normally single-band products. Compared to VoWiFi, Small Cells provide a more reliable carrier-grade coverage solution to a localised area, however they also require a robust broadband connection – usually directly to the carrier providing the Small Cell because the system effectively becomes a tiny part of the carrier’s network and must therefore comply with security protocols etc. Because Small Cells are carrier-specific, they are unlikely to be a cost-effective solution where the requirement is to provide coverage for all four carrier networks. Small Cell solutions work well for spot-coverage applications in a smaller office environment where all parties use the same carrier as their mobile service provider. In residential locations, the typical domestic arrangement often sees different members of a household using a different mobile service provider for a variety of reasons and consequently Small Cells may not be appropriate. Similarly, in public areas where the desire is to facilitate mobile service to visitors at a location (patrons, customers, clients, etc.) it is unlikely Small Cells will be the best approach.

### **Carrier Approved Mobile Signal Repeaters**

Carrier-approved mobile signal-repeater products take nearby external macro network mobile signal, then amplify and repeat that signal to a localised indoor area. There are different grades of mobile signal repeater with different RF power levels for particular purposes. In the case of low-capacity DAS solutions it is sometimes possible for carriers to reduce costs by installing carrier-grade repeaters which source “donor” signal from a nearby carrier base station rather than installing a dedicated carrier base station at the premises.

Repeater solutions are unlikely to be suitable for multiple Carriers due to the different Carrier donor site positions requiring different antenna orientations to receive the donor signal. Additionally, repeaters need to be “tuned” to work properly with the Carrier network so they do not create interference. There are not many cost-effective repeater products capable of supporting multiple Carriers, so multiple repeaters with multiple rooftop antennas would typically be required for this type of solution.

DAS performance using repeaters will also vary depending on the level of network congestion experienced by the Carrier donor site.

### **Smart Antennas**

Smart Antennas are consumer-available mobile signal-repeater products which have been specifically tested and approved by Carriers for use on their network. Essentially these products are carrier-specific and may or may not support multiple frequency bands or technologies. The same limitations as discussed in the Small Cell section apply to Carrier-approved Smart Antennas.

With the use of smart antennas or signal repeaters in particular, it is important to understand the statutory requirements for the use of these devices. It is a Commonwealth offence to transmit radio frequency without a license or the explicit permission of the licensee. There is widespread distribution and marketing of unauthorised and illegal signal repeater/booster products on the internet, sometimes to unsuspecting people who do not understand these products are illegal. Use of unapproved mobile signal repeater products or boosters cause interference to carrier operations and are quickly identified by the carriers because they impair network performance and affect other network users. These matters are always reported to the Commonwealth authorities. Statutory fines and prosecution may apply.

In addition to statutory penalties for operation of a repeater without authorisation by the mobile operator holding the relevant spectrum licence for the band, the mobile operator can directly sue the interfering person for any loss suffered. The financial loss caused by a crude repeater taking out an entire cell for a prolonged period of time, could be substantial.

### **Category 1 Antennas**

A category 1 antennae is an antennae which has been tested and used in a IBC and does not need to have RF assessment apart from the original test